



- (51) International Patent Classification:
F24J 2/04 (2006.01)
- (21) International Application Number:
PCT/US2010/040739
- (22) International Filing Date:
1 July 2010 (01.07.2010)
- (25) Filing Language: English
- (26) Publication Language: English
- (30) Priority Data:
61/222,516 2 July 2009 (02.07.2009) US
- (71) Applicant (for all designated States except US): **E. I. du Pont de Nemours and Company** [US/US]; 1007 Market Street, Wilmington, Delaware 19898 (US).
- (72) Inventors; and
- (75) Inventors/Applicants (for US only): **REISDORF, Raymond Joseph** [BE/BE]; 107 Rue Du Centre, B-6717 Nobressart, Attert (BE). **MORRIS, Bryan** [NZ/NZ]; 12 Rue Des Cordiers, CH-1207 Geneve (NZ).
- (74) Agent: **REYNOLDS, Stephen, E.**; E. I. du Pont de Nemours and Company, Legal Patent Records Center, 4417 Lancaster Pike, Wilmington, Delaware 19805 (US).
- (81) Designated States (unless otherwise indicated, for every kind of national protection available): AE, AG, AL, AM, AO, AT, AU, AZ, BA, BB, BG, BH, BR, BW, BY, BZ, CA, CH, CL, CN, CO, CR, CU, CZ, DE, DK, DM, DO, DZ, EC, EE, EG, ES, FI, GB, GD, GE, GH, GM, GT, HN, HR, HU, ID, IL, IN, IS, JP, KE, KG, KM, KN, KP, KR, KZ, LA, LC, LK, LR, LS, LT, LU, LY, MA, MD, ME, MG, MK, MN, MW, MX, MY, MZ, NA, NG, NI, NO, NZ, OM, PE, PG, PH, PL, PT, RO, RS, RU, SC, SD, SE, SG, SK, SL, SM, ST, SV, SY, TH, TJ, TM, TN, TR, TT, TZ, UA, UG, US, UZ, VC, VN, ZA, ZM, ZW.
- (84) Designated States (unless otherwise indicated, for every kind of regional protection available): ARIPO (BW, GH, GM, KE, LR, LS, MW, MZ, NA, SD, SL, SZ, TZ, UG, ZM, ZW), Eurasian (AM, AZ, BY, KG, KZ, MD, RU, TJ, TM), European (AL, AT, BE, BG, CH, CY, CZ, DE, DK, EE, ES, FI, FR, GB, GR, HR, HU, IE, IS, IT, LT, LU, LV, MC, MK, MT, NL, NO, PL, PT, RO, SE, SI, SK, SM, TR), OAPI (BF, BJ, CF, CG, CI, CM, GA, GN, GQ, GW, ML, MR, NE, SN, TD, TG).
- Published:
— without international search report and to be republished upon receipt of that report (Rule 48.2(g))

(54) Title: BUILDING-INTEGRATED SOLAR-PANEL ROOF ELEMENT SYSTEMS

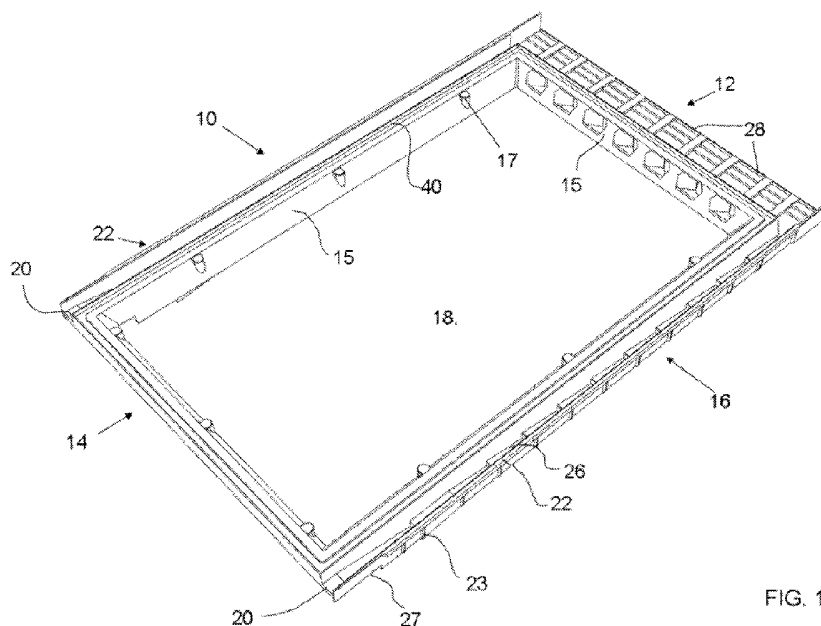

FIG. 1

(57) Abstract: The present invention provides a building-integrated solar-panel roof element, such as a photovoltaic (BIPV) roof element, adapted to be fitted with a solar panel and integrated in a pitched roof, as well as such a building-integrated roof element fitted with a photovoltaic or solar thermal panel, and an array of these solar energy roof elements mounted on a pitched roof.

WO 2011/002973 A2

TITLE OF INVENTION

BUILDING-INTEGRATED SOLAR-PANEL ROOF ELEMENT SYSTEMS

5

FIELD OF THE INVENTION

The present invention relates to the field of integrated solar-panel roofing systems, in particular photovoltaic systems.

BACKGROUND OF THE INVENTION

Due to increasing environmental concerns, alternatives to non-renewable and polluting fossil fuels have been investigated. Solar energy has received increasing attention as an alternative renewable, non-polluting energy source, and photovoltaic installations on commercial and residential roofs are becoming increasingly popular. The majority of existing installations to date consist of non-integrated systems. These systems generally consist of an array of photovoltaic or solar thermal modules attached on top of an existing roof covering.

“Add-on” structures can be installed on any type of roofing as “stand alone” solar systems. However, such systems typically require separate support structures that are bolted together to form an array of larger solar panels. Further, “add-on” solar panels are heavy and are more costly to manufacture, install and maintain. For example, the assembly of the arrays is typically done on-site or in the field rather than in a factory. Mounting arrays onto the roof may also require structural upgrades to the building.

Building Integrated Photovoltaics “BIPV” differ in that they act as roof covering and photovoltaic solution in one. BIPV solutions are required to interface with current roof coverings such as tiles, slates and metal roofing. This is because the whole surface of a roof is rarely used for power generation. The term “building-Integrated” is commonly used in the solar panel industry to differentiate this type of installation from that of a non-integrated system. This term implies that the photovoltaic or thermal solar panels constitute structural elements of a roof.

This invention is concerned particularly with integrated systems of

the BIPV or solar thermal type, that are applicable to new roofs and can also be adapted to existing roofs.

Commonly used materials for photovoltaic panels include glass (as a support and protection for potentially delicate wafers) and extruded aluminum frames which are cut and assembled around the glass in much the same way as a picture frame. These assemblies are then attached to the roof by means of brackets. Some BIPV solutions on the market require a specific roof covering to be used, which diminishes the choice for a customer. Some other products on the market try to address this gap, however the choice of roof covering is often limited, and the installation can often be very time consuming in order to guarantee water-tightness of the installation. Other problems are that it is complicated to integrate some systems in standard sloped roofs; there are complications for installation and de-installation; and size limitations may lead to increased installation costs because installing many small panels is more labor intensive. Similar considerations apply to the installation of thermal solar panels.

US patent publication 2006/0196128 describes a mounting for solar panels that are inclined in asymmetric frames where a wedge-like bottom of one frame fits under a thick end of another frame, the frames being connected side-by-side by protruding interlocking fixings. The frame is a small unit designed to be moulded from recycled plastic.

US patent publication 2006/0042680 describes a BIPV structure with a plastic frame around a PV laminate, mounted on a polymer substrate for fitting on a rafter. This requires a complicated sealing arrangement.

WO 2008/052816 describes an integrated modular photovoltaic element designed to match with classic tiles, the element comprising a lower hollow structural part of plastic material and an upper convex element of light-transparent material. This structure is relatively complex.

US patent 7,012,188 describes a BIPV framing system for solar panels made up of interconnected frame elements joined with a capping element over facing edges. This design requires a supplementary

polymeric sealing strip.

SUMMARY OF THE INVENTION

The invention provides a building-integrated solar-panel roof element, such as a photovoltaic (BIPV) roof element, adapted to be fitted
5 with a solar panel and integrated in a pitched roof, as well as such a building-integrated roof element fitted with a photovoltaic or solar thermal panel, and an array of these solar energy roof elements mounted on a pitched roof.

The invention aims to provide a building integrated system roof
10 element which:

- is universal and compatible to any kind of tiles or slates;
- can be easily dismantled but also mounted back, without disrupting the other elements making up the complete covering of the roof;
- is adapted to be surrounded by a flashing system that allows for
15 waterproofing of the system;
- does not need an undertile system which often leads to waterproof problems;
- can be made to any convenient size which combines ease of handling with reduced installation costs.

20 According to a main aspect, the invention provides a building-integrated solar-panel roof element, in particular a photovoltaic (BIPV) roof element, adapted to be fitted with a photovoltaic or other solar panel and integrated in a pitched roof, the roof element comprising an open generally-rectangular moulded polymer frame having a top edge, a bottom
25 edge and two side edges defining therebetween a central rectangular opening, the frame further having an outer face and an inner face. The invention provides one or more of the following features.

The side edges of the frame each have an integrally-moulded outside part in the form of a generally U-shaped profile that is open in the
30 direction of the frame's outer face. This outside part of the frame has at or towards its outside an upstanding longitudinal side wall, such that the side walls extend along the respective side edge whereby adjacent side-by-side elements can be placed with their adjacent side walls in facing

relationship.

The top edge and the bottom edge of the frame are so configured that the elements can be placed on a pitched roof with the top edge of one element against the bottom edge of an adjacent element that is placed
5 above and in extension of said one element, with these top and bottom edges overlapping or interengaging with one another.

Each roof element is arranged so that when a plurality of the elements each fitted with a photovoltaic or other solar panel are integrated in a pitched roof with the side walls of adjacent side-by-side elements in
10 facing relationship and with the top and bottom edges respectively of adjacent lower and upper elements overlapping or interengaging with one another, the elements can be mounted on the roof by means of fitting brackets engaging with the side walls of the elements, to form a generally planar solar panel array from which any one of the elements can be
15 dismantled and re-installed without interfering with the in-place mounting of the other elements of the array.

Another aspect of the invention is an array of building-integrated roof elements as set out above, with photovoltaic or solar thermal panels fitted in the elements and mounted on a pitched roof with the side walls of
20 adjacent side-by-side elements in facing relationship, and secured to the roof by brackets engaging the adjacent side walls of the adjacent side-by-side roof elements.

Further aspects of the invention are set out in the following description and in the claims.

25 BRIEF DESCRIPTION OF THE DRAWINGS

The invention will be further described by way of example with reference to the accompanying schematic drawings, in which:

Fig. 1 is a perspective view from above the polymeric frame;

Fig. 2 is a perspective view showing the underside of the polymeric
30 frame;

Fig. 3 is a cut-away perspective view from above one corner of the lower part of the polymeric frame;

Fig. 4 is a cross-sectional view showing a fixing bracket on the

facing sidewalls of two side-by-side adjacent roof elements, and the securing to a roof batten;

Fig. 5 is a perspective view from above one inner corner of the bottom of a polymeric frame;

5 Fig. 6 is a perspective view from above one inner corner of the top of a polymeric frame, illustrating air vents;

Fig. 7 is a perspective view of the underside of the polymeric frame showing the top edge and part of the two side edges;

10 Fig. 8 is a side view showing the bottom part of the polymeric frame with integral projections for positioning the frame relative to roof battens;

Fig. 9A and Fig. 9B are cut-away perspective views illustrating the assembly of the top of one frame with the bottom of another;

Fig. 10 is a broken-away perspective view of a connecting piece;

15 Fig. 11 a cut-away perspective view from above one corner of the lower part of another embodiment of polymeric frame showing an aperture in the frame adapted for when the frame is fitted on a full boarded roof;

Fig. 12 is a perspective view showing a roof element installed on a roof with a flashing system; and

20 Fig. 13 is an exploded perspective view showing a lateral flashing element for a full boarded roof.

DETAILED DESCRIPTION

The drawings show by way of example a photovoltaic system according to the present invention that comprises a polymeric frame 10 for supporting in particular a photovoltaic module. For installation on a roof, 25 the polymeric frame supports and is attached to a photovoltaic or solar thermal module by an adhesive interface.

The drawings show a building-integrated photovoltaic (BIPV) roof element that is adapted to be fitted for example with a photovoltaic panel and integrated in a pitched roof, the roof element comprising an open 30 generally-rectangular moulded polymer frame 10 having a top edge 12, a bottom edge 14 and two side edges 16 defining therebetween a central rectangular opening 18, the frame 10 further having an outer face (shown in Fig. 1) and an inner face (shown in Fig. 2).

The side edges 16 of frame 10 each have an integrally-moulded outside part in the form of a generally U-shaped profile 20 that is open in the direction of the frame's outer face and has at or towards its outside an upstanding longitudinal side wall 22. The side walls 22 extend along the
5 respective side edge 16 whereby adjacent side-by-side elements can be placed with their adjacent side walls 22 in facing relationship, as shown in Fig. 4.

The top edge 12 and the bottom edge 14 of frame 10 are so configured that the elements can be placed on a pitched roof with the top
10 edge 12 of one element against the bottom edge 14 of an adjacent element that is placed above and in extension of said one element, with these top and bottom edges 12,14 overlapping or interengaging with one another. For this, the bottom ends of the side walls 22 have recessed parts 27 defining spaces for receiving the top end of the side walls 22 of
15 adjacent elements, as illustrated in Figs. 9A and 9B.

Each roof element is arranged so that when a plurality of the elements whose frames 10 are each fitted with a photovoltaic panel are integrated in a pitched roof with the side walls 22 of adjacent side-by-side elements in facing relationship and with the top and bottom edges 12,14
20 respectively of adjacent lower and upper elements overlapping or interengaging with one another, the elements can be mounted on the roof by means of metal fitting brackets 24 engaging with the side walls 22 (see Fig. 4). As a result of this configuration, the elements can form a generally planar photovoltaic array from which any one of the elements can be
25 dismantled and re-installed without interfering with the in-place mounting of the other elements of the array.

Each side edge 22 of frame 10 has, on its inner face adjacent to the bottom edge, an integrally-moulded projection 29 (Fig. 8) for engaging against a roof batten to position the roof element relative to the roof
30 batten. Should the roof be a full boarded roof, i.e. a roof that does not comprise roof battens and counter battens, the side edge 22 of frame 10 does not need to comprise the integrally-moulded projections 29.

The inner periphery of the edges 12,14,16 of the frame 10 has an

integrally-moulded flared skirt 15 (Fig. 1) that widens towards the inner face of frame 10. On this skirt 15 can be seen a plurality of injection points 17 that result from the injection moulding process. These injection points 17 do not constitute functional elements of the frame 10.

5 **Material used to manufacture the frame**

The thermoplastic composition used to manufacture the polymeric frame 10 comprise a thermoplastic resin such as for example polypropylenes; polyamides and semi-aromatic polyamides; polyesters such as for example poly(ethylene terephthalate) (PET), poly(1,4-butylene terephthalate) (PBT) and poly(1,4-cyclohexyldimethylene terephthalate) (PCT); liquid crystalline polymer (LCP) such as for example polyesters, poly(ester-amides) and poly(ester-imides); polyphenylene sulfides (PPS); polycarbonates (PC); and polyvinyl chlorides (PVC). Other materials like polyurethane (PU) in homogeneous or foamed form are also possible.

15 The thermoplastic composition used to manufacture the polymeric frame 10 may further comprise modifiers and other ingredients, including, without limitation, ultraviolet light stabilizers, flame retardants, impact modifiers, flow enhancing additives, lubricants, antistatic agents, coloring agents, nucleating agents, crystallization promoting agents and other processing aids known in the polymer compounding art.

20 The polymeric frame 10 may be manufactured by shaping the thermoplastic composition described above. By "shaping", is meant any shaping technique, such as for example extrusion, injection moulding, thermoform moulding or compression moulding and / or any kind of flexible moulding like silicon moulding obtained by stereo litho or other technique, or by casting a polymer resin into a mould. Preferably, however, the polymeric frame is shaped by injection moulding.

Design of the frame

30 The edges 12,14,16 of frame 10 have an open alveolar structure that opens into the inner face of the frame, as shown in Figs. 2 and 7. This alveolar structure is defined by a plurality of integrally-moulded triangulated ribs 46 along the sides 16 and the inside of top edge 12 and the bottom edge 14, that extend towards the open inner face of the

frame's edges. Further step-like ribs 26 are provided along the bottoms of the channels 20 (except that these ribs 26 are absent or less pronounced along the bottom ends of the channel 20, as shown in Figs. 1 and 3) , and yet further shallow step-like ribs 28 are provided in the top ends 12. The thus-designed polymeric frame 10 provides sufficient torsional rigidity so as to prevent damage to the potentially delicate photovoltaic module. It is also designed so as to provide resistance to physical loading of the frame under such conditions as snow coverage or lift from high winds when the elements are installed on a roof.

10 The polymeric frame 10 further has moulded in features (namely the side walls 22) that act as an interface between adjacent panels. The frame 10 also has moulded in features that are used in conjunction with brackets 24 to anchor the panel, and adjacent panels to the underlying roof structure 30, as shown in Fig. 4.

15 The top and bottom edges 12,14 are arranged such that the bottom edge 14 of an upper element fits in overlapping relationship over the top edge 12 of an adjacent lower element, with the recessed part 27 of the bottom edge 14 fitting inside the end parts of walls 22 on the upper edge 12, as shown in Figs. 9A and 9B. The top edges 12 have apertures 13 that form air passages allowing the upflow of air from under the lower element to under the upper element. These apertures 13 are further arranged to prevent the ingress of water. Air flow is possible both for air entering through the adjacent panels, and for air passing under the panels. This feature of the invention consists of allowing enough ventilation under the back of the glass module to limit the increase of the temperature in between acceptable limits. The air venting apertures 13 are located right at the overlap of each panel to the next in the vertical direction.

25 As can be seen on Fig. 5, in the region of the bottom edge 14 of the frame, the bottom edge of the skirt 15 is raised relative to the bottom edge of the skirt 15 along the side edges. This raised part of the skirt edge in the bottom edge 14 allows passage of the protruding part of the top end 12 of an adjacent element, as shown in Fig. 9B.

The polymeric frame 10 supports and secures the glass

photovoltaic module 60 (Figs. 4 and 9) and seals the roof by a fitment and embedding system between each panel in the top-bottom direction of the roof and with a specially designed sealing retaining profile 40/41 between each panel in the left to right direction.

5 The frames 10 of two side-by-side elements interface by means of a joint that ensures a waterproof seal between the two parts, as shown in Fig. 4. A plurality of U-shaped metal brackets 24 is used to attach the assembly to the roof structure 30 either on battens and/or counter battens or on the roof board when the roof element is fitted on a full boarded roof.

10 The brackets 24 are adapted to fit between and grip the facing side walls 22 of adjacent side-by-side elements, the central connecting wall of each bracket 24 having an aperture for receiving an attachment member, namely a screw 36 to attach the element to a roof 30. The brackets 24 can be compact U pieces or long U-section profiles as illustrated in Fig. 13 and

15 preferably have out-turned edges. For sealing purposes, an elongated strip-like profile 34 is adapted to engage over top parts 32 of adjacent side walls 22 of adjacent side-by-side elements, when the side walls are in facing relationship, as shown in Fig. 4, to form a substantially water-tight closure between the adjacent side-by-side elements. As shown, the top

20 part of profile 34 can have inwardly-directed flanges 35 that engage on the top of the brackets 24, and inwardly-directed flanges at its open ends, that engage with the out-turned edges of the brackets 24. The strip-like profile 34 is preferably made of the same thermoplastic composition that is used to manufacture the polymeric frame.

25 The length of the strip-like profile 34 can be adapted to the length of the polymeric frame and an intermediate connecting piece 38 (Figure 10) may be further used to connect the strip-like profiles 34 of an assembly of adjacent top-bottom elements. The connecting piece 38 is preferably made by injection moulding a thermoplastic composition. The bottom of

30 the strip-like profile 34 at the bottom of the installation may be closed by an adapted end cap 42 (Figs. 10 and 13). The adapted end cap 42 is preferably also made by injection moulding a thermoplastic composition. The top end of the connecting piece 38 is closed by a flashing, as

described below.

When an array of the elements is fitted on a roof, the elongated strip-like profile(s) 34 fit over top parts of the adjacent side walls 22 of facing adjacent side-by-side elements, the profile(s) 34 extending along all elements from top to bottom of the array, to form a substantially water-tight closure between the adjacent side-by-side elements. The said strip-like profiles 34 leave open the U-shaped profiles 20 that form rain drainage channels extending from top to bottom of the array. For this purpose, the step-like ribs 26 on the bottom of the channels are asymmetrically inclined with their top faces inclining downwards at a slope less than that of the pitched roof, so rain will drain down these channels 20 unobstructed.

There is also an integrally-moulded recessed channel 40 and ledge 41 (see Figs. 1 and 4) located around the inner periphery of the outer face of the frame 10, for receiving an edge of a photovoltaic panel 60 of corresponding dimensions to fit panel 60 in the frame 10, leaving a space around the edge to accommodate for manufacturing tolerances and thermal expansion.

As mentioned above, when the roof structure 30 comprises battens and counter battens, each side edge 22 of the frame 10 preferably has, on its inner face adjacent to the bottom edge, an integrally-moulded projection 29 for engaging against a roof batten and/or counter batten to position the roof element relative to the roof batten so that the frame 10 is blocked and secured in place against the batten. When the roof structure 30 does not comprise battens, i.e. when the roof structure is a full boarded roof, the integrally-moulded projection 29 can be dispensed with and can be replaced by an aperture 44 (Figure 11). This aperture 44 in the frame 10 allows a passage for wires, cables and/or tubing and acts as a cable tray channel but also may be used to render the horizontal installation of the BIPV roof element easier.

The design of the frame 10 may be easily adapted so as to allow a landscape positioning of rectangular BIPV roof elements, by moulding the U-shaped profiles of the side edges along the shorter sides of the rectangular frame. Square frames are also possible.

The invention also covers the described BIPV roof element with a rectangular photovoltaic panel 60 (see Fig. 12) fitted in the frame 10 by adhesive bonding of the edges of the panel to the inner periphery of the outside of the frame 10. Thermal solar panels can be fitted in the same way.

The solar panels

The roof element according to the invention can incorporate photovoltaic panels or thermal solar panels, according to the requirements.

Any suitable type of photovoltaic panel can be fitted in the roof element according to the invention. This includes see-through types as well as types with an opaque backing. The panel can be substantially non-flexible or partly flexible. Usually the photovoltaic panel comprises a glass or transparent or translucent outside panel supporting on its rear face a photovoltaic material or cells. Many photovoltaic panels use wafer thin crystalline silicon cells, or thin films based on cadmium telluride or silicon, for example. Generally, any of the commercially available photovoltaic panels can be used. Electrical connections to the photovoltaic elements can be made by a group of conductors extending for example from one corner of the underside of the panel.

When thermal solar panels are fitted, provision will be made for the passage of tubing to inlet/outlet circulating liquid driven thermodynamically or by a pump.

When glass-supported solar panels are used, this adds considerably to the weight of the roof element/photovoltaic panel assembly. Here the design of the frame 10 with its reinforcing alveolar structure plays an important role in maintaining the integrity of the assembly during handling, so that a single large panel can be handled by one or two persons, simplifying assembly and reducing installation costs because of the relatively large surface area of the panels.

Other elements

Additional elements of the panel include a junction box and connecting cables for the connection of the photovoltaic panels of adjacent

elements or to an inverter. For thermal solar panels, the frame will include suitable passages for tubing to inlet/outlet circulating liquid.

Attachment to the tiles and to the roof.

For most installations, the building integrated system according to the invention comprises a plurality of photovoltaic panels assembled together and attached to the roof using a plurality of brackets 24 for this purpose. The plurality of photovoltaic panels may be assembled together in such a way to form a rectangular shape assembly, a U-shape or inverted U assembly, an L-shape assembly or other shapes adapted to accommodate for the particular roof configuration, for instance to pass around obstacles like chimneys. The integration of the top part of one element on a roof is shown in Fig. 12.

It is also possible to install an isolated single element on an area of a roof, though this is more unusual.

A plurality of brackets 24 is used to attach the assembly to the roof structure 30 (see Figs. 4 and 12). The panel is intended to be used in conjunction with other identical panels in configurations that can be adapted to use some or all of the available space on a roof. The external border of these configurations is surrounded on all of its external sides by a flashing system 50 that allows for waterproofing of the system as a whole and integration with whichever roof covering is specified, such as tiles 52 as shown in Fig. 12, or slates.

The outermost side walls 22 of elements located at the outside of the array are held on the roof by brackets 56 that engage with the outermost side walls 22 and extend under an adjacent roof covering.

One or more flashing elements 50 extend from under the roof covering to engage with the outermost side walls, the uppermost top edge(s) and the lowermost bottom edge(s) of the elements. As shown in Fig. 12, a flashing element 50 extends along the top edge 14 of the element and over the U-shaped profiles 20 and outer wall 22 to a location where it will be covered by an adjacent tile (not shown). The external border of these configurations is thus surrounded by a flashing system 50 that allows for waterproofing of the system as a whole and integration with

whichever roof covering is specified (tiles, slates).

When the panels are fitted to a roof 30 that is fully boarded, it is required to have a specific lateral flashing element 54 of stepped shape which leaves a passage 55 for wires and cables (Fig. 13). In addition to
5 the specific lateral flashing element 54, and for mechanical reasons, L-shaped supports 56 can be further mounted against the outer faces of the side walls 22. Fig. 13 also shows a special metal bracket 24 of elongated U shape having several apertures for screws 36 in its central connecting part.

10

CLAIMS

What is claimed is:

1. A building-integrated solar-panel roof element adapted to be fitted with a solar panel and integrated in a pitched roof, the roof element
5 comprising an open generally-rectangular moulded polymer frame having a top edge, a bottom edge and two side edges defining therebetween a central rectangular opening, the frame further having an outer face and an inner face, wherein:
 - 10 - the side edges of the frame each have an integrally-moulded outside part in the form of a generally U-shaped profile that is open in the direction of the frame's outer face and has at or towards its outside an upstanding longitudinal side wall, the side walls extending along the respective side edge whereby adjacent side-by-side elements can be placed with their adjacent side walls in
15 facing relationship,
 - the top edge and the bottom edge of the frame are so configured that the elements can be placed on a pitched roof with the top edge of one element against the bottom edge of an adjacent element that is placed above and in extension of said one element, with these
20 top and bottom edges overlapping or interengaging with one another, and
 - each roof element is arranged so that when a plurality of the elements each fitted with a solar panel are integrated in a pitched roof with the side walls of adjacent side-by-side elements in facing
25 relationship and with the top and bottom edges respectively of adjacent lower and upper elements overlapping or interengaging with one another, the elements can be mounted on the roof by means of fitting brackets engaging with the side walls of the elements, to form a generally planar solar panel array from which
30 any one of the elements can be dismantled and re-installed without interfering with the in-place mounting of the other elements of the array.
2. The solar-panel roof element of claim 1, wherein the top and bottom

edges are arranged such that the bottom edge of an upper element fits in overlapping relationship over the top edge of an adjacent lower element, the bottom and top edges having apertures and/or profiles that form an air passage or passages allowing the upflow of air from under the lower
5 element to under the upper element.

3. The solar-panel roof element of claim 1 or 2, wherein the edges of the frame have an open alveolar structure that opens into the inner face of the frame, this alveolar structure being defined by a plurality of integrally-
10 moulded ribs that extend towards the open inner face of the frame's edges.

4. The solar-panel roof element of claim 1, 2 or 3, wherein the inner periphery of the edges of the frame has an integrally-moulded flared skirt
15 that widens towards the inner face of the frame.

5. The solar-panel roof element of claim 1, 2 or 3, wherein the inner periphery of the edges of the frame has at least one aperture for allowing a passage to wires, cables and/or tubing.
20

6. The solar-panel roof element of any preceding claim, wherein the bottom of the generally U-shaped profile in each side edge of the frame has a series of angulated steps along its length.

7. The solar-panel roof element of any preceding claim, wherein each side edge of the frame has, on its inner face adjacent to the bottom edge, an integrally-moulded projection for engaging against a roof batten to position the roof element relative to the roof batten.
25

8. The solar-panel roof element of any preceding claim, in combination with at least one elongated strip-like profile that is/are adapted to engage with top parts of adjacent side walls of adjacent side-by-side elements, when the side walls are in facing relationship, to form a substantially water-tight closure between the adjacent side-by-side
30

elements.

9. The solar-panel roof element of any preceding claim, in combination with brackets adapted to fit between and grip the adjacent
5 side walls of adjacent side-by-side elements, when the side walls are in facing relationship, each bracket having an aperture for receiving an attachment member to attach the bracket to a roof.

10. The solar-panel roof element of any preceding claim, wherein there
10 is an integrally-moulded recessed channel and/or ledge located around the inner periphery of the outer face of the frame, for receiving an edge of a solar panel of corresponding dimensions to fit the solar panel in the frame.

15 11. The solar-panel roof element of any preceding claim, further comprising a rectangular photovoltaic or solar thermal panel fitted in the frame by adhesive bonding of the edges of the panel to the inner periphery of the outside of the frame.

20 12. An array of solar-panel roof elements according to claim 11 mounted on a pitched roof with the side walls of adjacent side-by-side elements in facing relationship, and secured to the roof by brackets engaging the adjacent side walls of the adjacent side-by-side roof elements.

25 13. The array of solar-panel roof elements of claim 12, wherein at least one elongated strip-like profile fits over top parts of the adjacent side walls of adjacent side-by-side elements that are in facing relationship, one or more of said strip-like profiles extending along all elements from top to
30 bottom of the array to form a substantially water-tight closure between the adjacent side-by-side elements, leaving open the U-shaped profiles that form rain drainage channels extending from top to bottom of the array.

14. The array of solar-panel roof elements of claim 12 or 13, wherein

the outermost side edges of elements located at the outside of the array are held on the roof by brackets that engage with the outermost side walls and extend under an adjacent roof covering.

- 5 15. The array of solar-panel roof elements of claim 14, wherein one or more flashing elements extend from under the roof covering to engage with the outermost side walls, the uppermost top edge(s) and the lowermost bottom edge(s) of the elements.

FIG. 1

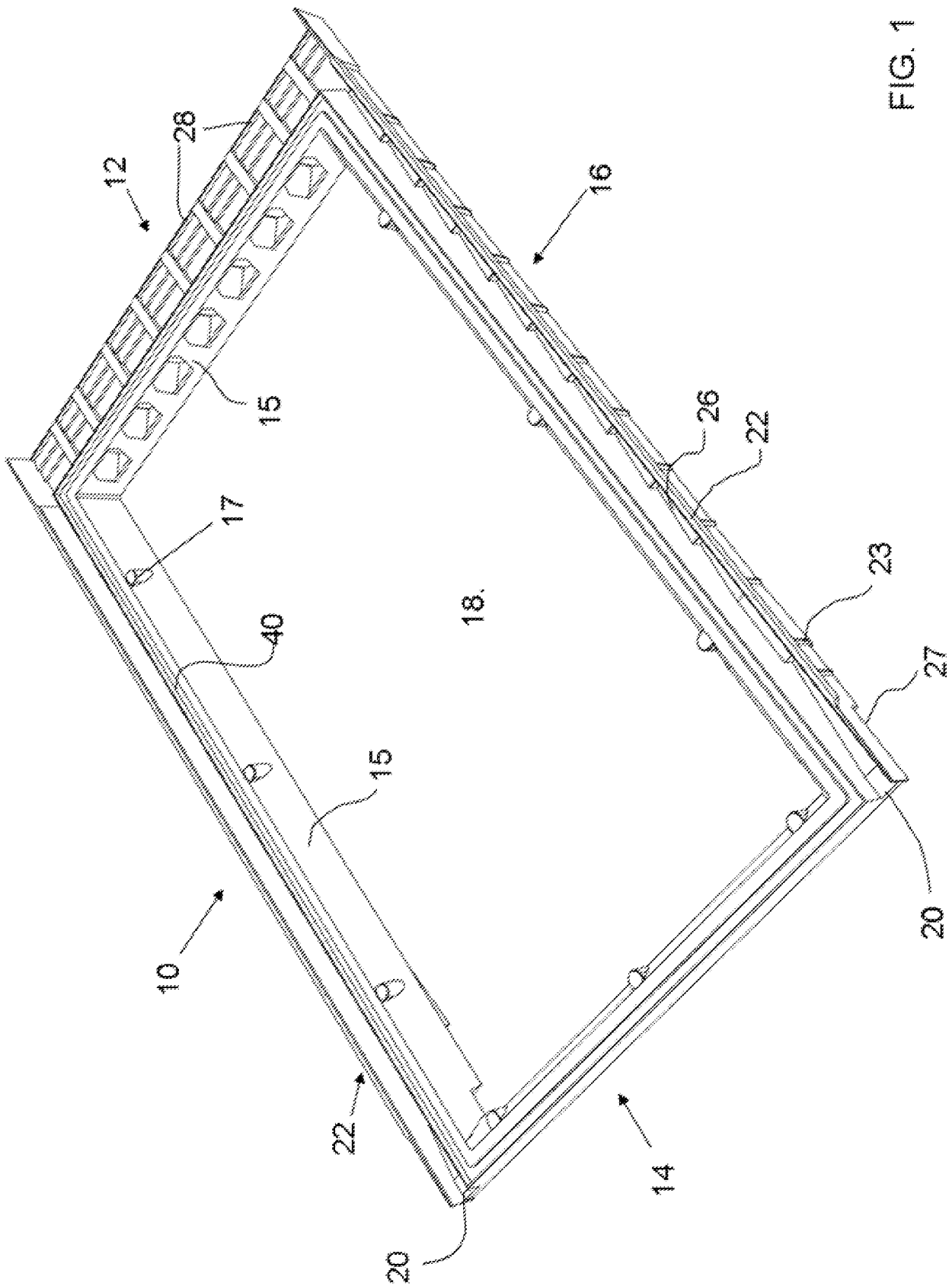

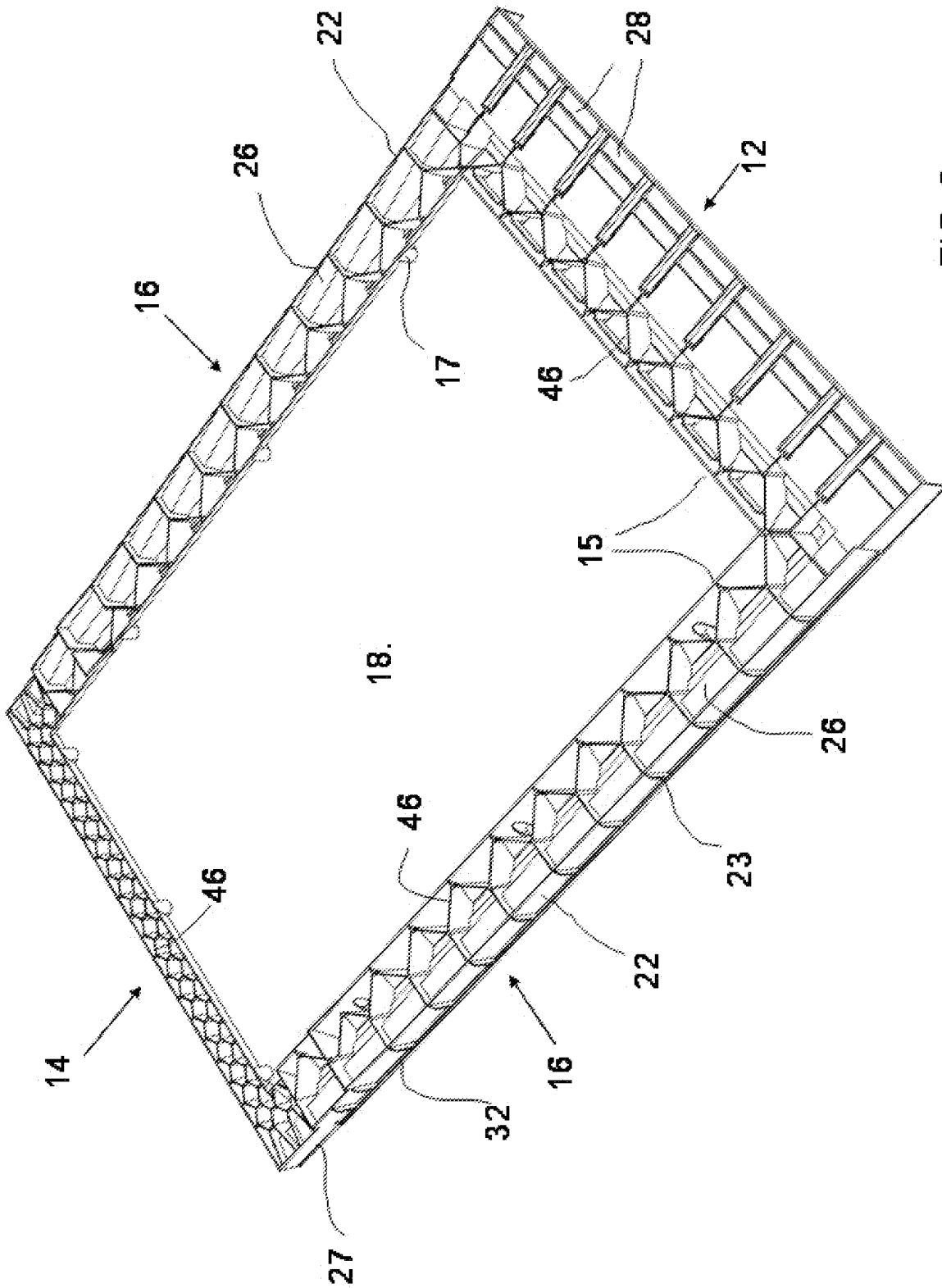

FIG. 2

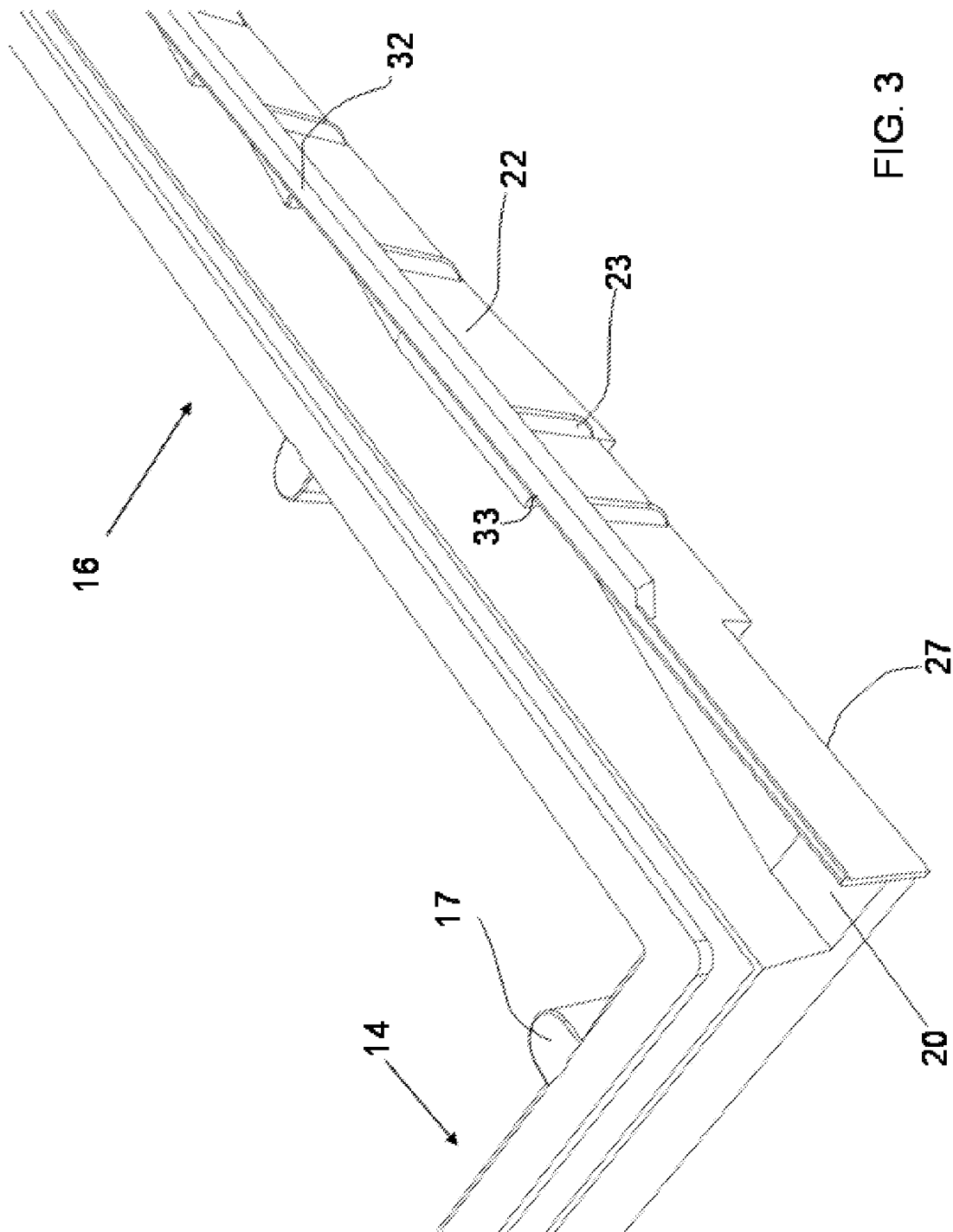
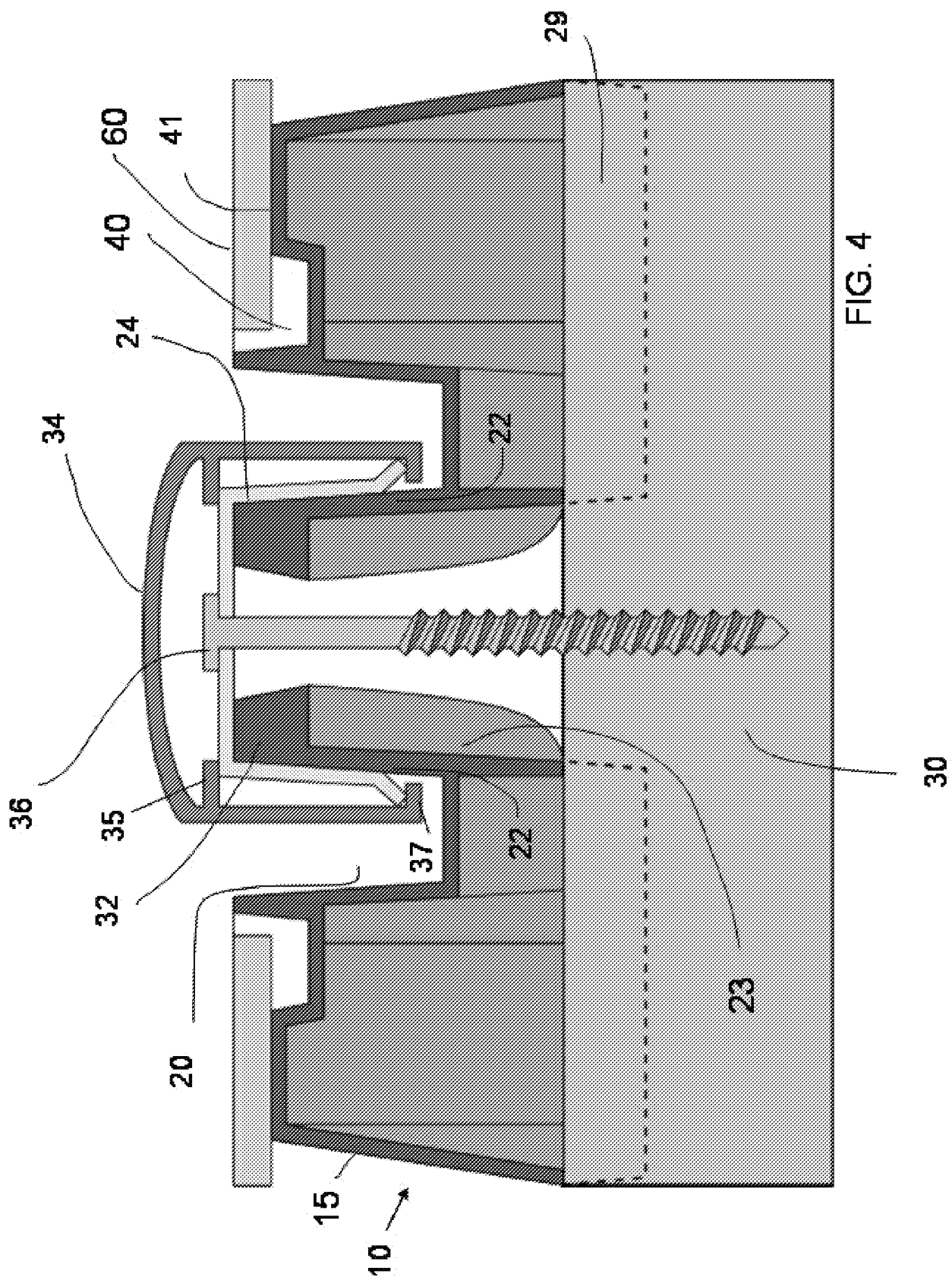

FIG. 3



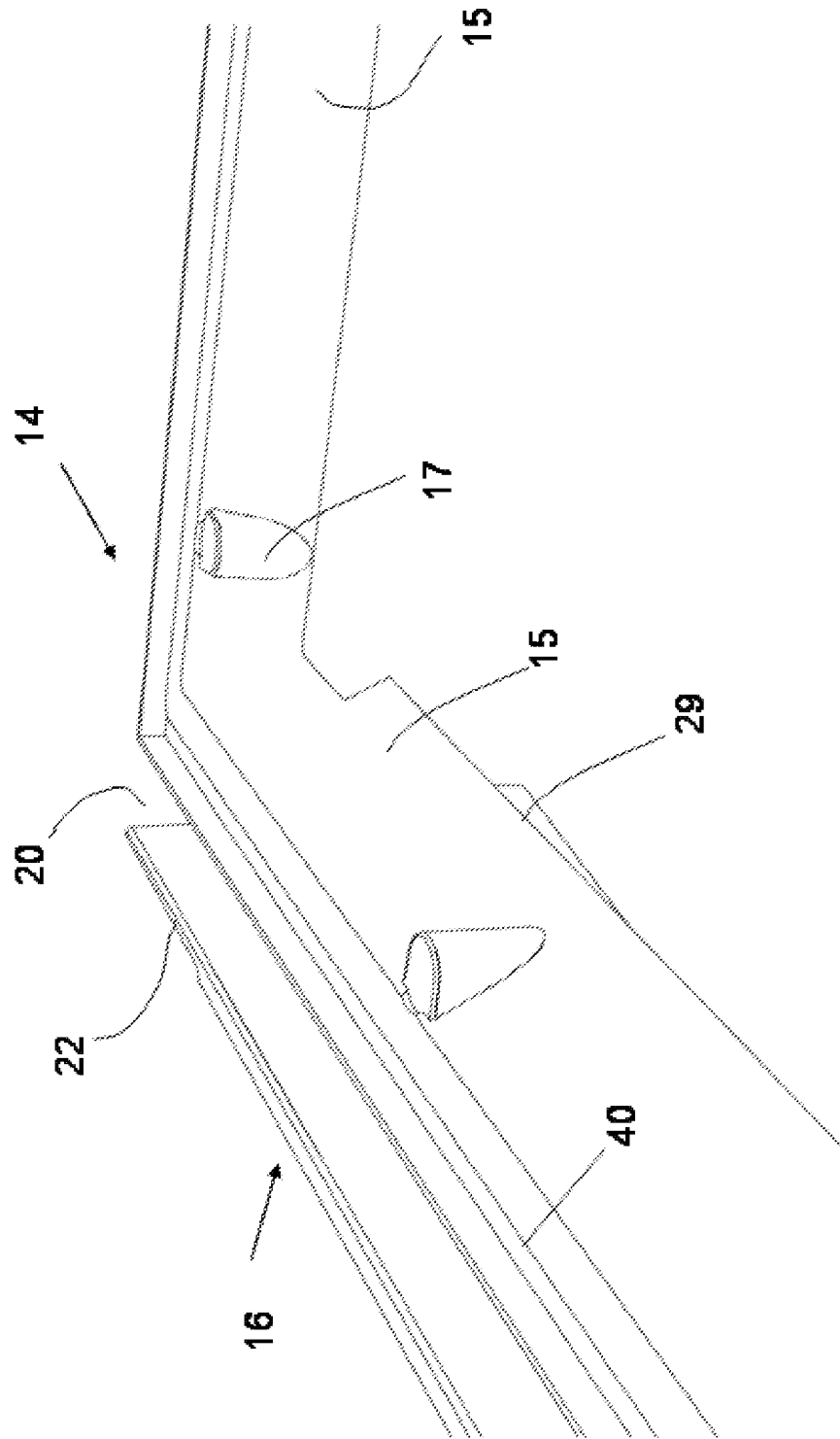

FIG. 5

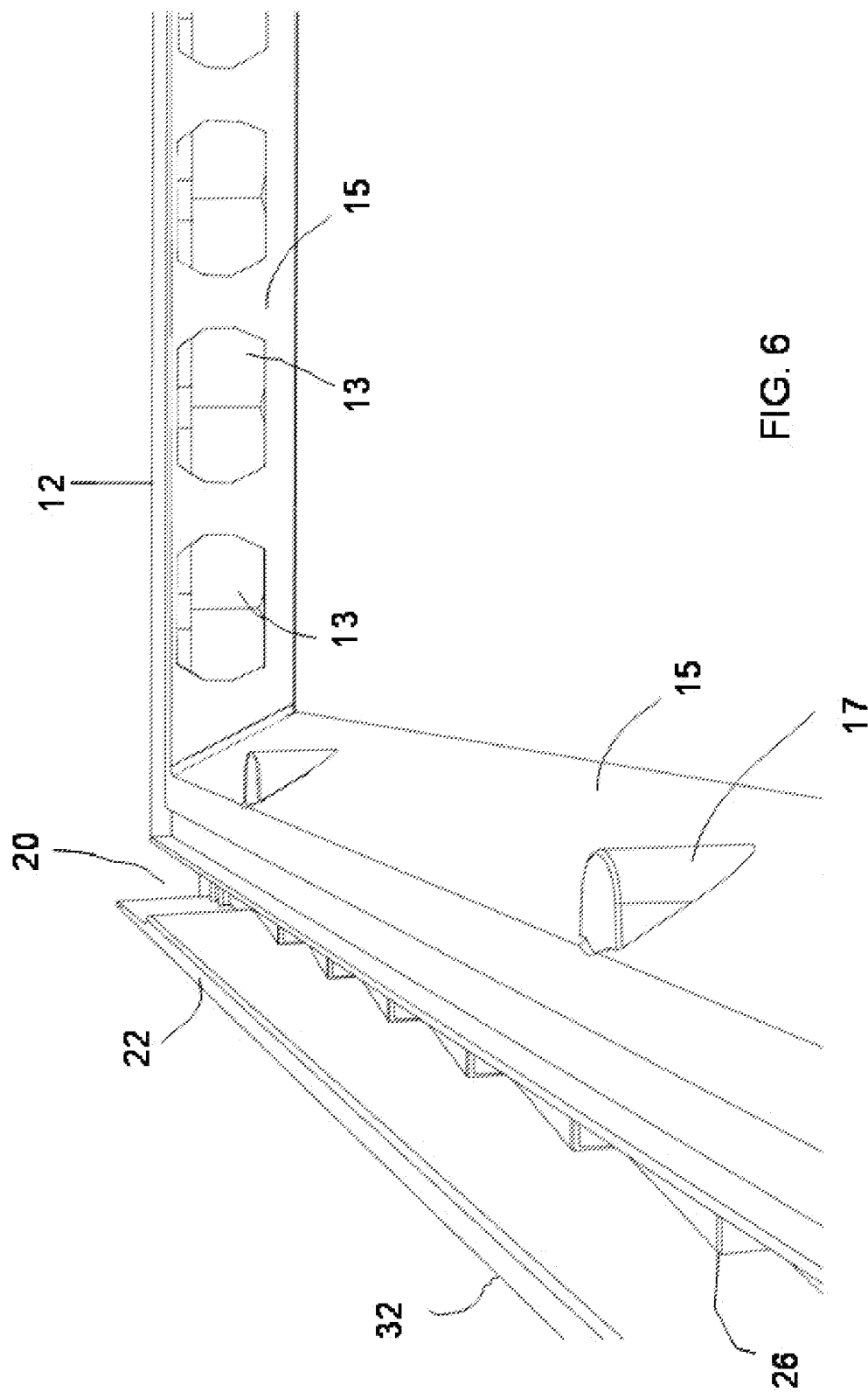

FIG. 6

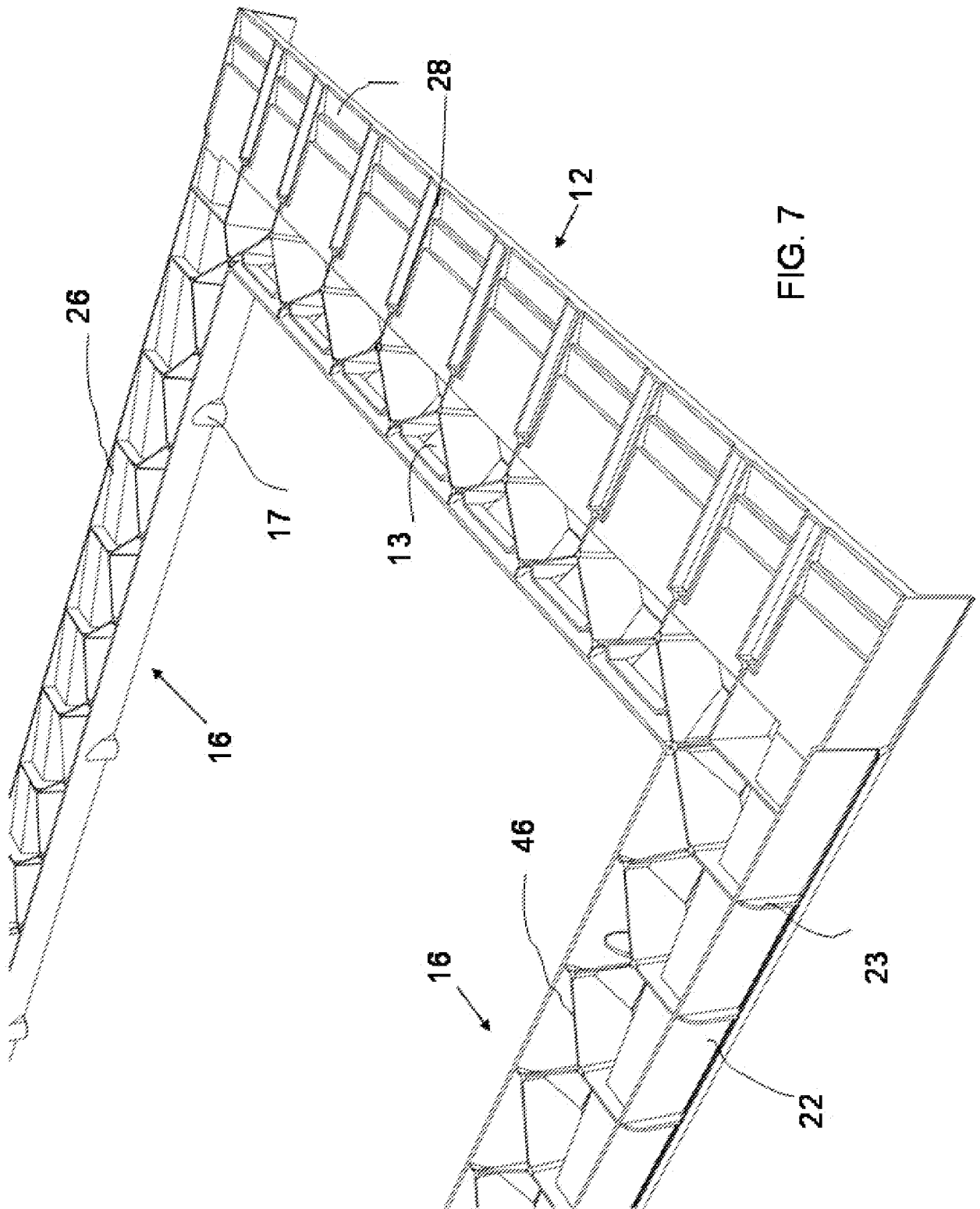

FIG. 7

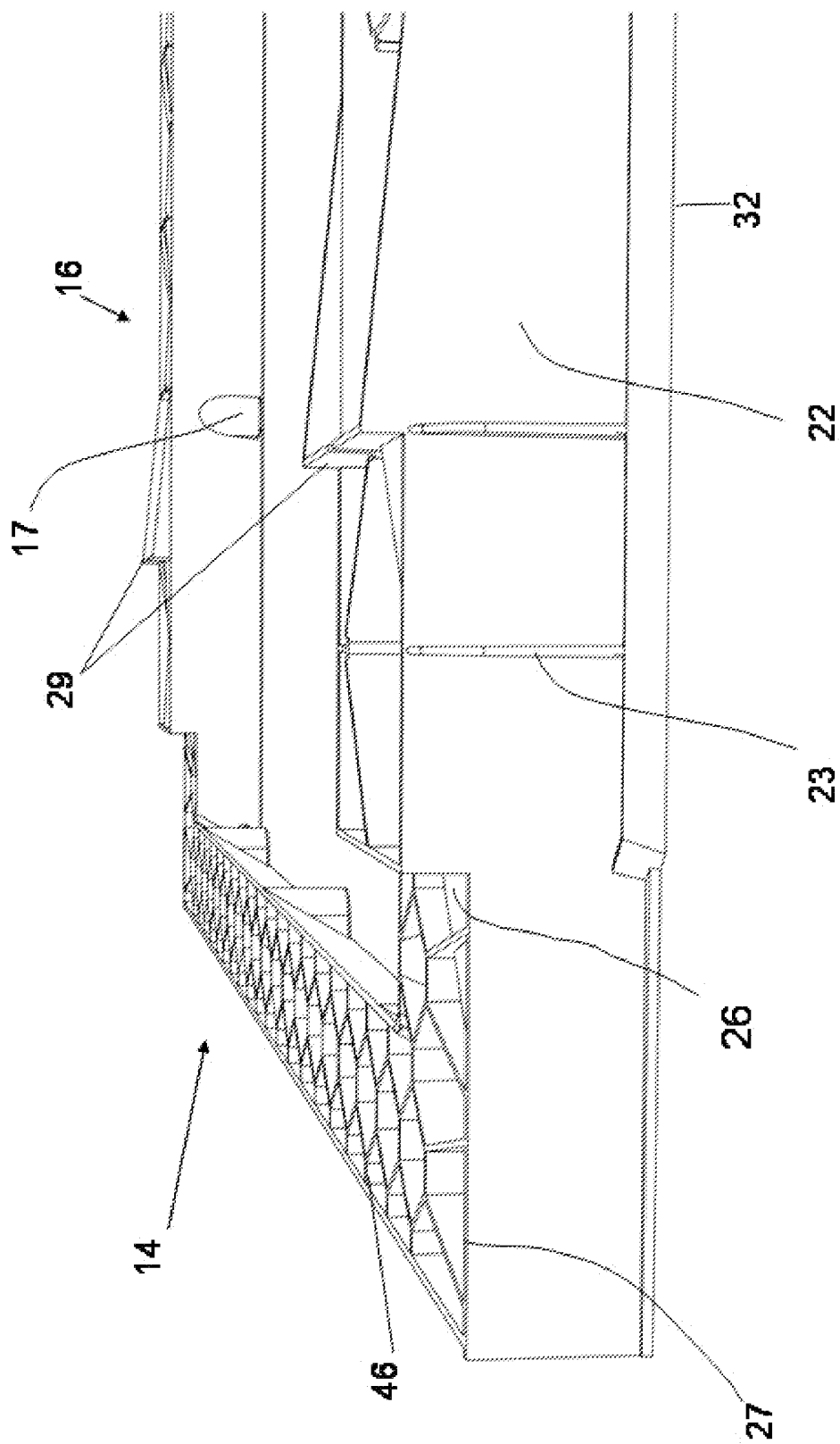

FIG. 8

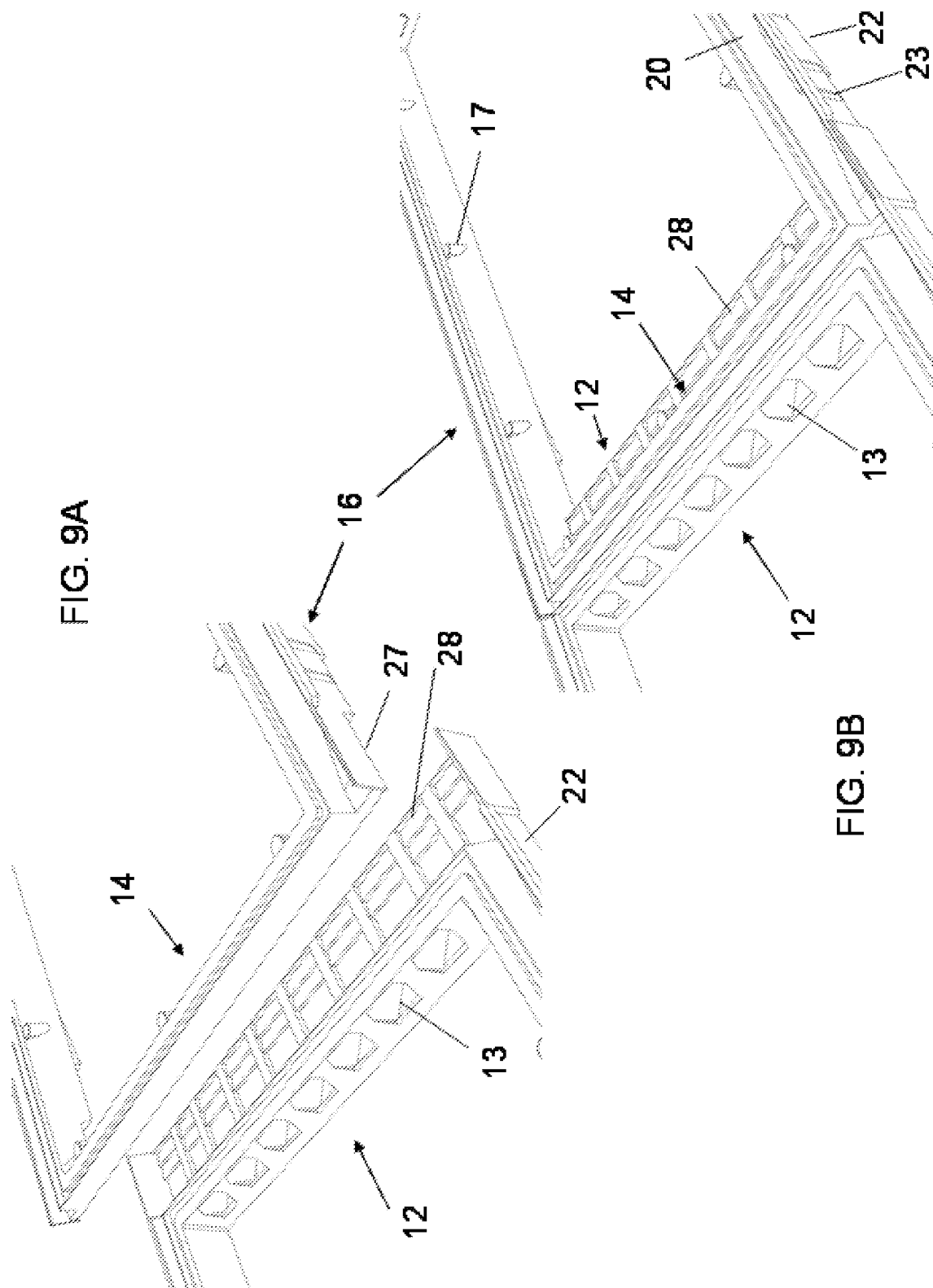

FIG. 9A

FIG. 9B

10/13

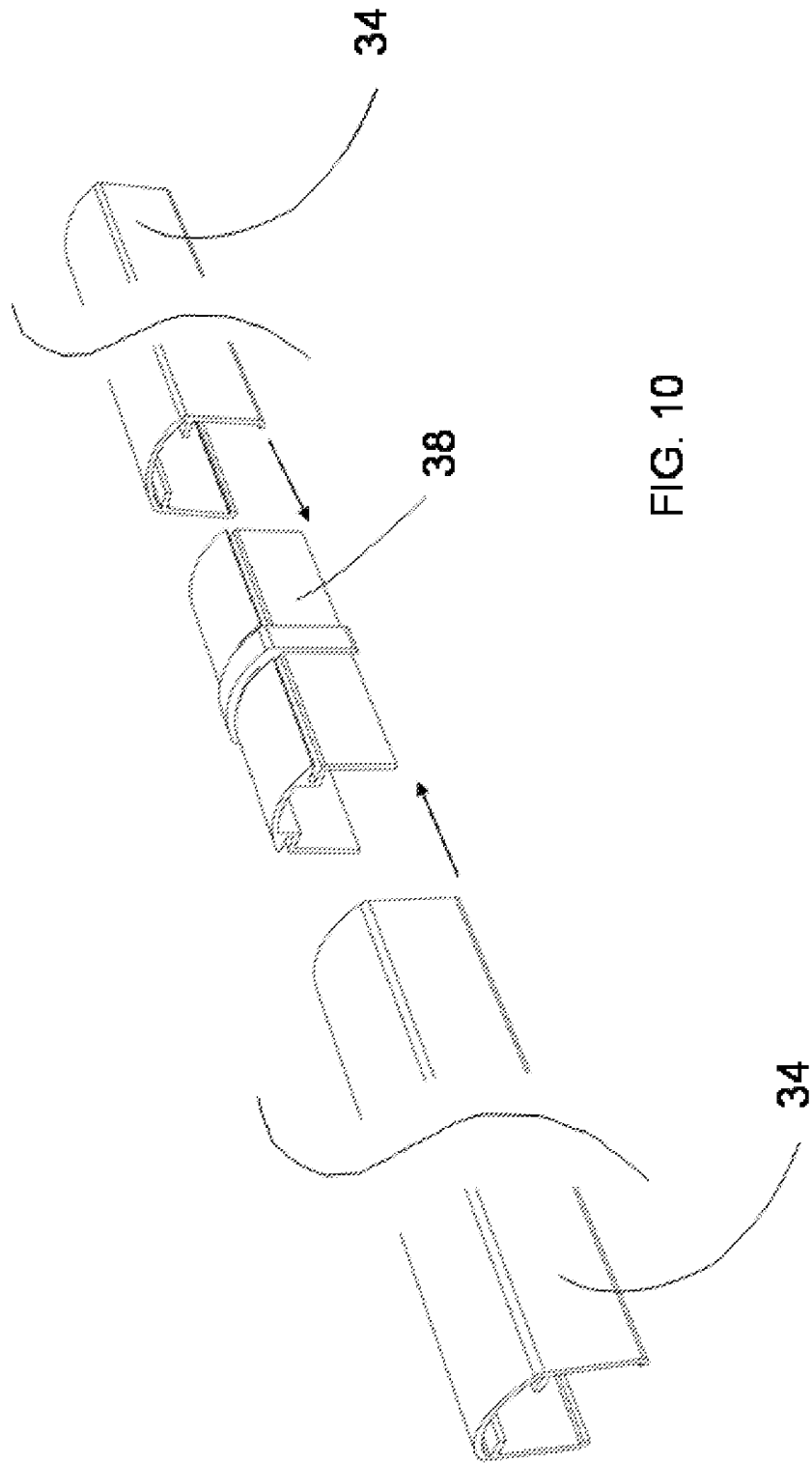

FIG. 10

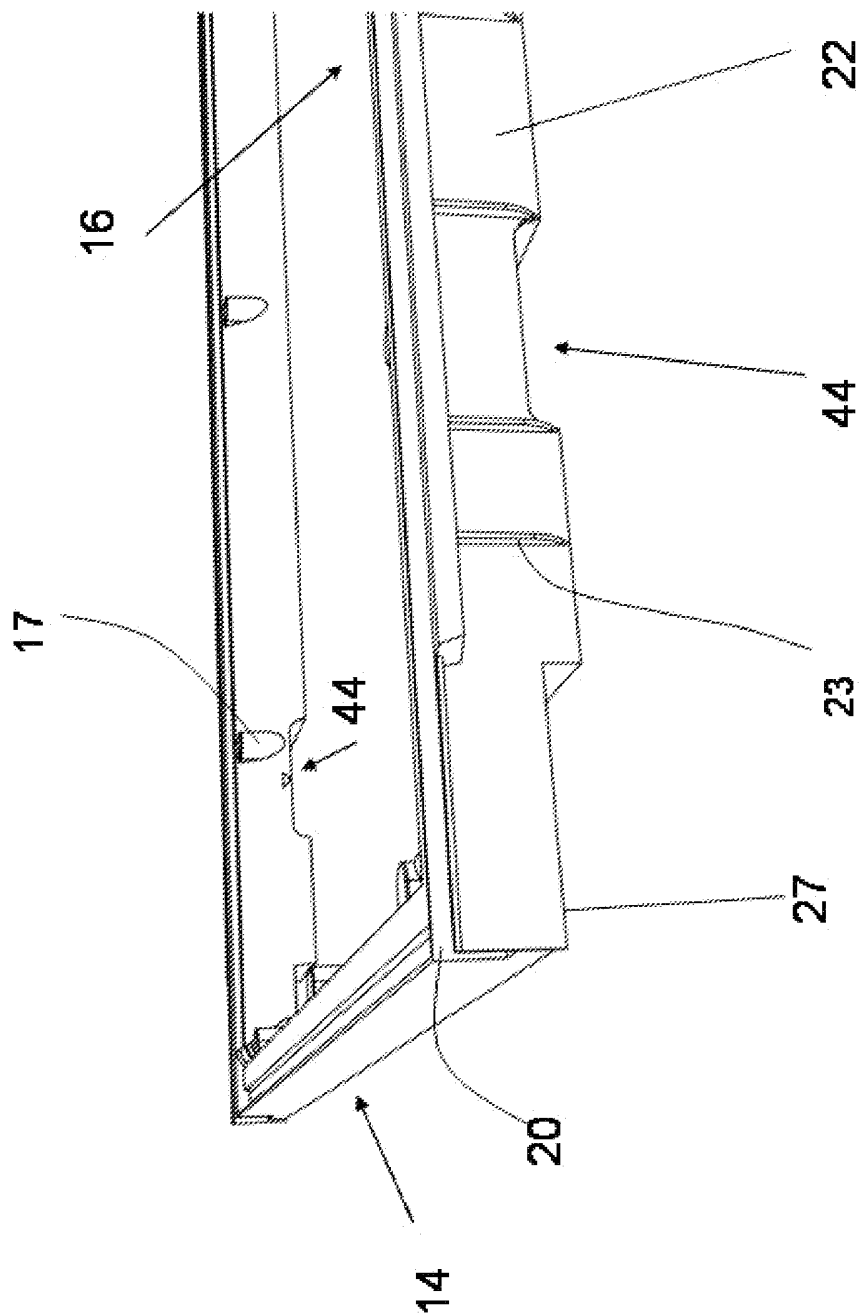

FIG. 11

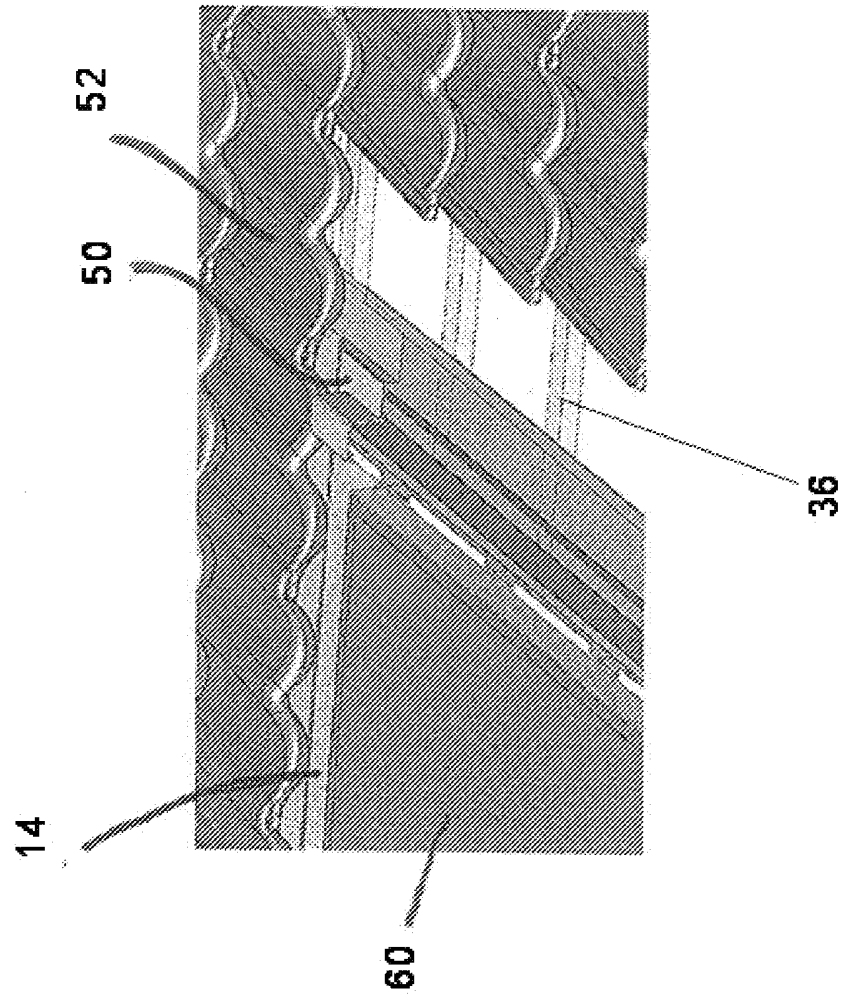

FIG. 12

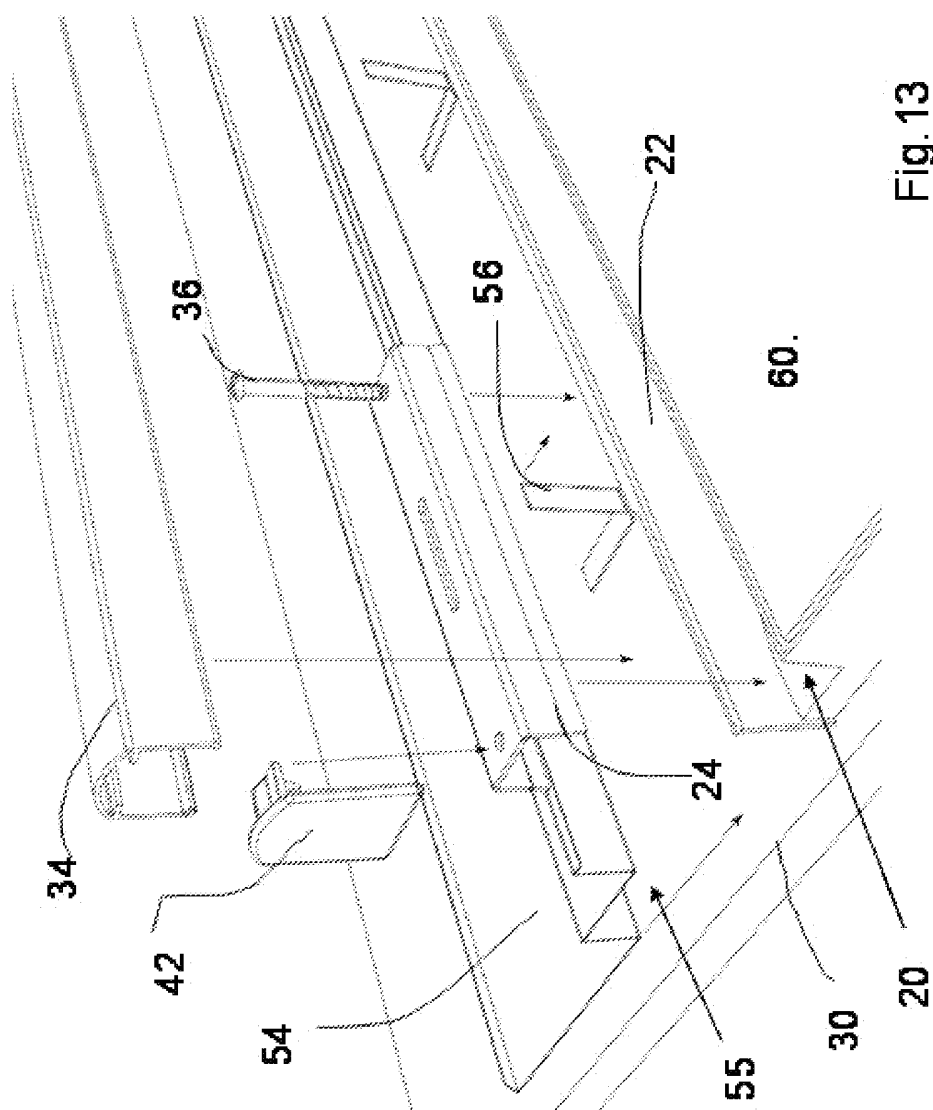

Fig. 13