



(11) **EP 2 338 934 A1**

(12) **EUROPEAN PATENT APPLICATION**

(43) Date of publication: **29.06.2011 Bulletin 2011/26** (51) Int Cl.: **C08K 3/00 (2006.01)**

(21) Application number: **10195942.7**

(22) Date of filing: **20.12.2010**

(84) Designated Contracting States:  
**AL AT BE BG CH CY CZ DE DK EE ES FI FR GB GR HR HU IE IS IT LI LT LU LV MC MK MT NL NO PL PT RO RS SE SI SK SM TR**  
Designated Extension States:  
**BA ME**

(72) Inventors:  
• **Manicke, Paul Stephen**  
**Cincinnati, OH 45215 (US)**  
• **Walker, Bryant Edward**  
**Cincinnati, OH 45215 (US)**  
• **Ronk, Warren Rosal**  
**Cincinnati, OH 45215 (US)**

(30) Priority: **23.12.2009 US 289751 P**  
**30.06.2010 US 827841**

(74) Representative: **Gray, Thomas**  
**GE International Inc.**  
**Global Patent Operation - Europe**  
**15 John Adam Street**  
**London WC2N 6LU (GB)**

(71) Applicant: **General Electric Company**  
**Schenectady, NY 12345 (US)**

(54) **Slurry composition**

(57) A ceramic matrix composite precursor slurry composition includes a thermosetting resin, a suitable curing agent, a ceramic component, a carbonaceous solids component, and optionally, a suitable solvent. The thermosetting resin may be a polyester, a vinyl ester, an epoxy resin, a bismaleimide resin, and/or a polyamide resin. The carbonaceous solids component provides a

suitable amount of carbon char upon pyrolyzation. The precursor slurry composition may comprise up to about 70 volume% solids after removal of the solvent, and prior to cure. A sheet molding compound first and second outer films comprising the precursor slurry composition and randomly dispersed reinforcing material carried between the first and second outer films.

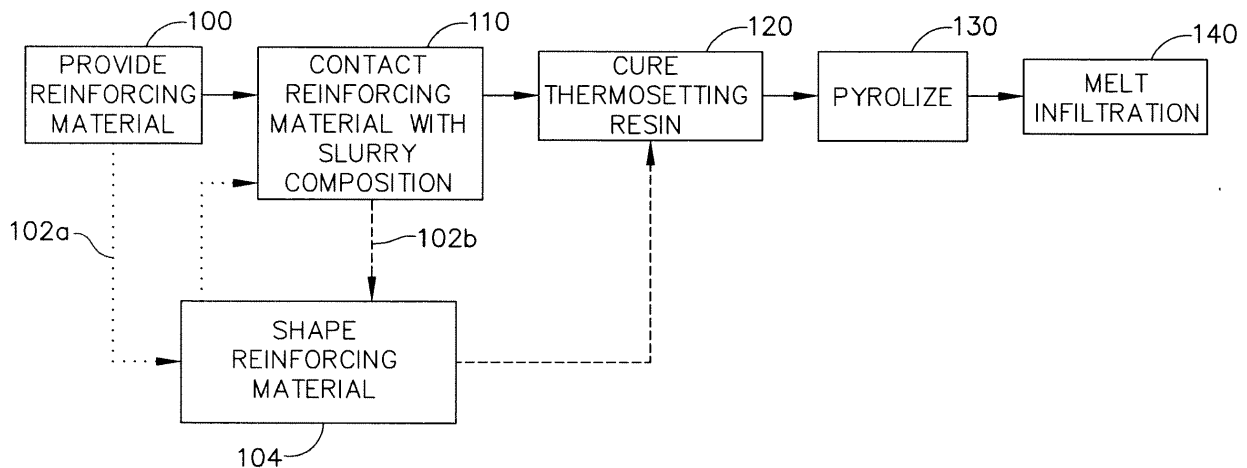

FIG. 2

EP 2 338 934 A1

**Description**

## CROSS REFERENCE TO RELATED APPLICATIONS

## BACKGROUND OF THE INVENTION

**[0001]** This invention relates generally to precursor slurry compositions for producing ceramic matrix composite (CMC) articles and a sheet molding compound, and more particularly to slurry compositions utilizing fast curing thermosetting resins.

**[0002]** CMC materials generally comprise a ceramic fiber reinforcement material embedded in a ceramic matrix material. The reinforcement material serves as the load-bearing constituent of the CMC in the event of a matrix crack, while the ceramic matrix protects the reinforcement material, maintains the orientation of its fibers, and serves to dissipate loads to the reinforcement material. Of particular interest to high-temperature applications are silicon-based composites, such as silicon carbide (SiC) as the matrix and/or reinforcement material. SiC fibers have been used as a reinforcement material for a variety of ceramic matrix materials, including SiC, TiC, Si<sub>3</sub>N<sub>4</sub>, and Al<sub>2</sub>O<sub>3</sub>.

**[0003]** One technique for fabricating CMCs involves multiple layers of "prepreg," often in the form of a tape-like structure, comprising the reinforcement material of the desired CMC impregnated with a precursor of the CMC matrix material. Prepregs may comprise a two-dimensional fiber array comprising a single layer of unidirectionally-aligned tows impregnated with a matrix precursor to create a generally two-dimensional laminate. Multiple plies of the resulting prepregs are stacked and debulked to form a laminate preform, a process referred to as "lay-up." The prepregs are typically arranged so that fiber tows of the prepreg layers are oriented transverse (e.g., perpendicular) to each other, providing greater strength in the laminate plane of the preform, corresponding to the principal or load-bearing direction of the final CMC component. Following lay-up, the laminate preform will typically undergo debulking and curing while subjected to applied pressure and an elevated temperature, such as in an autoclave.

**[0004]** The preform may be heated in vacuum or in an inert atmosphere in order to decompose the organic binders, at least one of which pyrolyzes during this heat treatment to form a carbon char, and produces a porous preform for melt infiltration. During melt infiltration, molten silicon infiltrates into the porous preform, reacts with the carbon constituent of the matrix to form silicon carbide, and fills the porosity to yield the desired CMC component.

**[0005]** One process is described in U.S. Patents 5,015,540; 5,330,854; and 5,336,550. As described therein, the reinforcing fibers in the preform are coated with a low char yield slurry composition containing polymers that decompose upon heating. The polymers produce little or no char, which means that there is little or no solid material after burnout, resulting in a low strength

preform. Thus there is a need for an improved preform with high strength after burn-out.

**[0006]** In order to address the need for a stronger and tougher preform after burnout, U.S. Patent 6,258,737 describes a process for forming a CMC article using a high char yielding resin slurry composition. Although operable, this disclosed process provides an opportunity for process and product improvement, especially for reduced cycle time and minimized solvent-induced defects.

## BRIEF DESCRIPTION OF THE INVENTION

**[0007]** The above-mentioned need or needs may be met by exemplary embodiments which provide resin systems selected for processibility and green strength. The selected resin systems greatly reduce the need for solvents and therefore solvent processing requirements. Exemplary embodiments employ solvents that are readily removed from the system. Exemplary embodiments utilize increased levels of organic binders or other fillers to provide the desired carbon char levels.

**[0008]** An exemplary embodiment includes a precursor slurry composition for forming a ceramic matrix composite article. The precursor slurry composition comprises a thermosetting resin, a suitable curing agent, a ceramic component, a carbonaceous solids component, and optionally, a suitable solvent. The thermosetting resin is at least one member selected from a polyester, a vinyl ester, an epoxy resin, a bismaleimide resin, and a polyamide resin. The carbonaceous solids component provides a suitable amount of carbon char upon pyrolyzation. Exemplary precursor slurry composition may include up to about 70 volume% solids after removal of the solvent, and prior to cure.

**[0009]** An exemplary embodiment includes a sheet molding compound including first and second outer films comprising a precursor slurry composition; and randomly dispersed reinforcing material being carried between the first and second outer films. The precursor slurry composition comprises a thermosetting resin, a suitable curing agent, a ceramic component, a carbonaceous solids component, and optionally, a suitable solvent. The thermosetting resin is at least one member selected from a polyester, a vinyl ester, an epoxy resin, a bismaleimide resin, and a polyamide resin. The carbonaceous solids component provides a suitable amount of carbon char upon pyrolyzation. The final char yield comprises the resin char yield and the carbon char attributable to the carbonaceous solids component. Exemplary precursor slurry composition may include up to about 70 volume% solids after removal of the solvent, and prior to cure.

## BRIEF DESCRIPTION OF THE DRAWINGS

**[0010]** The subject matter which is regarded as the invention is particularly pointed out and distinctly claimed in the concluding part of the specification. The invention, however, may be best understood by reference to the

following description taken in conjunction with the accompanying drawing figures in which:

FIG. 1 is a perspective view of an exemplary CMC component.

FIG. 2 is a flowchart of an exemplary process for forming a CMC article.

#### DETAILED DESCRIPTION OF THE INVENTION

**[0011]** Referring to the drawings, FIG. 1 shows an exemplary ceramic matrix composite component 10 particularly adapted for use in a gas turbine engine assembly. Component 10 includes an airfoil portion 12 against which a flow of gas is directed. The airfoil 10 is mounted to a disk (not shown) by a dovetail 14 that extends downwardly from the airfoil portion 12 and engages a slot of complementary geometry on the disk. The airfoil has a leading edge section 18 and a trailing edge section 16. Such a composite airfoil is fabricated by laying up a plurality of plies. Those with skill in the art will readily appreciate that embodiments disclosed herein may be widely adapted to produce other ceramic matrix composite components.

**[0012]** In an exemplary embodiment, composite component 10 may be formed by exemplary processes disclosed herein and schematically represented in FIG. 2. In an exemplary embodiment, reinforcing material such as silicon carbide-containing fibers may be provided (Step 100), for example, as bundled in tows. The reinforcing material may be formed into complex shapes to form the fiber preform which serves as a base for forming the final CMC article. As is known in the art, the fibers may be provided with boron nitride and/or other coating (e.g., silicon-wetting coatings). In an exemplary embodiment, the fibers may be characterized as "continuous lengths" meaning fiber lengths greater than or equal to 1 centimeter. Other exemplary embodiments may provide reinforcing material as non-continuous or chopped fibers. In other exemplary embodiments fiber tows may be directly laid up on tooling, for example in processes known in the art as filament winding.

**[0013]** In an exemplary embodiment, the reinforcing material is contacted with an exemplary slurry composition (Step 110). In certain exemplary embodiments, the reinforcing material is contacted with the slurry composition prior to shaping into a preform (Step 104), for example as a prepreg tape or laminate. In other exemplary embodiments, the reinforcing material may be initially shaped (Step 104) and then infused with an exemplary slurry composition. In other words, the reinforcing materials are contacted with an exemplary slurry composition either after being shaped into a preform, as indicated by the dotted line 102a, or before shaping indicated by dashed line 102b.

**[0014]** An exemplary slurry composition includes a fast-cure thermosetting resin system, which, after curing

(Step 120), provides a cured preform having desired green strength and toughness. Further, the thermosetting resin system may be selected to require minimal solvent additions that must be removed during cure. The thermosetting resin system may be selected to cure very quickly, as compared to other resin systems currently used in forming CMC components. In an exemplary embodiment, the resin system may cure in 7-10 minutes, with substantially all the solvent, if used, being removed before cure. The reduced solvent provides opportunities for improved dimensional control, especially when forming high tolerance components, e.g., turbine blades and shrouds. An additional advantage of the exemplary thermosetting resin systems is the opportunity to use closed die molding techniques due to more constant volume. The quick cure cycles provides fast turn around times on the molding equipment. Additionally, reduced solvent loads result in lower bulk so that during the shaping/molding process there is reduced opportunities for slips or wrinkles, resulting in improved repeatability.

**[0015]** Exemplary resins are polyesters, vinyl esters, epoxy resins, or other fast-curing thermosetting resins. An exemplary slurry composition includes a polyester resin, a suitable curing agent (e.g., benzoyl peroxide), a ceramic component (e.g., SiC), and a carbonaceous solids component including organic binders or other fillers. The carbon filler loading is generally higher than a level used in the high char resin systems referenced above in order to achieve a comparable carbon yield. For example, carbon-containing fillers in known high char resin systems may be about 27 volume %. In exemplary embodiments disclosed herein, preforms, prior to cure, may include carbon fillers at levels up to about 60-70 volume% by utilizing solvent (e.g., acetone) prior to shaping and removing the solvent prior to cure. Other exemplary embodiments may include the carbonaceous solids component at levels greater than about 30 volume%. Exemplary carbonaceous material may include graphite particles, flakes, whiskers, or fibers of amorphous, single crystal or poly-crystalline carbon, carbonized plant fibers, lamp lack, finely divided coal, charcoal, and carbonized polymer fibers or felt such as rayon poly-acrylonitrile, and polyacetylene. Ideally, the resin(s) provide adequate flow without requiring significant amount of solvent. "Adequate flow" may be determined by the processing requirements such as the flow required to consolidate the resin system during the cure stage. Other processing methods, such as mixing the slurry to a homogenous mixture or winding into a tape may require lower viscosity than consolidation. Those with skill in the art will appreciate the flow requirements for the desired outcomes. Exemplary embodiments may include acetone or other easily removed solvent. Benzoyl peroxide or other agents may be utilized to initiate polymerization of the resin(s).

**[0016]** Removal of substantially all the solvent, if used, prior to cure, and use of a relatively fast curing thermosetting resin promotes substantially total cure, providing dimensional stability to the preform. The cured preform

is pyrolyzed (Step 130) as is known in the art to yield a porous fiber structure for subsequent processing. Pyrolyzation yields carbon content for subsequent reaction with molten silicon to form the silicon-silicon carbide composite.

**[0017]** An exemplary melt infiltration process (Step 140) is disclosed in U.S. Patent No. 4,737,328, which is incorporated herein by reference. Sufficient molten silicon infiltrate is infiltrated into the preform to produce the composite component. Specifically, the molten silicon infiltrant is mobile and highly reactive with elemental carbon to form silicon carbide. The period of time required for infiltration may be determined empirically and depends largely on the size of the preform and extent of infiltration required. Thereafter, the resulting infiltrated body is cooled under conditions (atmosphere and cooling rate) to avoid significant deleterious effects. It is envisioned that pyrolyzation and silicon melt infiltration may be performed in a continuous operation, or in separate operations as understood by those having skill in the art.

**[0018]** The temperature range for melt infiltration may be from about 1400 °C to about 1800 °C, preferably between about 1400 °C and 1450 °C. The preform may be placed on a carbon wick that is supported on a boron-nitride coated graphite plate. Silicon (e.g., as 95% SiC-5% B alloy) may be placed on the wick in an amount sufficient to completely saturate the wick and fill the preform when molten.

**[0019]** After cooling, the infiltrated composite body may be removed from the attached carbon wick (largely converted to silicon carbide and silicon) by known techniques such as cutting and grinding with diamond abrasive wheels. Exemplary composite bodies have high density (e.g., not greater than about 3% porosity).

**[0020]** Thus, there is provided a process for quickly forming a porous preform having sufficient residual carbon char and reinforcement material into which molten Si may be infused to form the SiC matrix. The porous preform may comprise a near net shape incorporating complex features not readily obtainable by prior methods.

**[0021]** In an alternate embodiment, a sheet molding compound is disclosed. An exemplary sheet molding compound includes reinforcing material of randomly dispersed chopped fibers, for example chopped coated SiC tow bundles typically about 1-5 cm in length, sandwiched between opposing films of the ceramic precursor slurry (i.e., the thermosetting resin system as discussed above). The fast curing thermosetting resin is used to obtain both flow in the mold and green strength after molding but prior to pyrolyzation. The CMC precursor sheet molding compound can be subsequently processed to suitable green strength, for example, by compression molding. The thicker final form of the CMC sheet molding compound material along with the material's ability to flow and crosslink can reduce CMC component processing time by several hours.

**[0022]** This written description uses examples to disclose the invention, including the best mode, and also to

enable any person skilled in the art to make and use the invention. The patentable scope of the invention is defined by the claims, and may include other examples that occur to those skilled in the art. Such other examples are intended to be within the scope of the claims if they have structural elements that do not differ from the literal language of the claims, or if they include equivalent structural elements with insubstantial differences from the literal languages of the claims.

## Claims

1. A precursor slurry composition **characterized by** a thermosetting resin; a suitable curing agent; a ceramic component; a carbonaceous solids component; and optionally, a suitable solvent; wherein the thermosetting resin is at least one member selected from a polyester, a vinyl ester, an epoxy resin, a bis-maleimide resin, and a polyimide resin, and wherein the carbonaceous solids component provides a suitable amount of carbon char upon pyrolyzation, and wherein the precursor slurry composition comprises up to 70 volume% solids after removal of the solvent, and prior to cure.
2. The precursor slurry composition according to claim 1 wherein the selected thermosetting resin is able to be cured in less than 15 minutes.
3. The precursor slurry composition according to any of the claims 1 and 2 wherein the carbonaceous solids component includes at least one member of the group consisting of graphite particles, graphite flakes, graphite whiskers, amorphous, single crystal or poly-crystalline carbon, carbonized plant fibers, lamp black, finely divided coal, charcoal, carbonized polymer fibers, and felt.
4. The precursor slurry composition according to any of the claims 1, 2 and 3 comprising:
  - a suitable amount of one or more additives selected from dispersants, thickening agents, crosslinking monomers, low profile additives and pigments.
5. The precursor slurry composition according to any of the claims 1, 2, 3 and 4 comprising:
  - 48 volume% acetone, 16 volume% of the carbonaceous solids component; 9 volume% of the ceramic component, a remainder being the thermosetting resin and the suitable solvent, if present.
6. A sheet molding compound including:

first and second outer films comprising a precursor slurry composition; and randomly dispersed reinforcing material being carried between the first and second outer films; wherein the precursor slurry composition comprises: 5

a thermosetting resin, a ceramic component, a carbonaceous solids component, and optionally, a suitable solvent, and a suitable curing agent, if present, 10  
 wherein the thermosetting resin is at least one member selected from a polyester, a vinyl ester, an epoxy resin, a bismaleimide resin, and a polyimide resin, and wherein 15  
 the carbonaceous solids component provides a suitable amount of carbon char upon pyrolyzation, and wherein the precursor slurry composition comprises up to 70 volume% 20  
 solids after removal of the solvent, and prior to cure.

7. The sheet molding compound according to claim 6 wherein the reinforcing material comprises SiC tow bundles of between 1 to 5 cm in length. 25
8. The sheet molding compound according to any of the claims 6 and 7 exhibiting a sufficient green strength following a compression molding process. 30
9. The sheet molding compound according to any of the claims 6, 7, and 8 wherein the carbonaceous solids component includes at least one member of the group consisting of graphite particles, graphite flakes, graphite whiskers, amorphous, single crystal 35  
 or poly-crystalline carbon, carbonized plant fibers, lamp black, finely divided coal, charcoal, carbonized polymer fibers, and felt.
10. The sheet molding compound according to any of the claims 6, 7, 8, and 9 wherein the precursor slurry composition comprises 48 volume% acetone, 16 volume% of the carbonaceous solids component; 9 volume% of the ceramic component, a remainder being 40  
 the thermosetting resin and the suitable curing agent, if present. 45

50

55

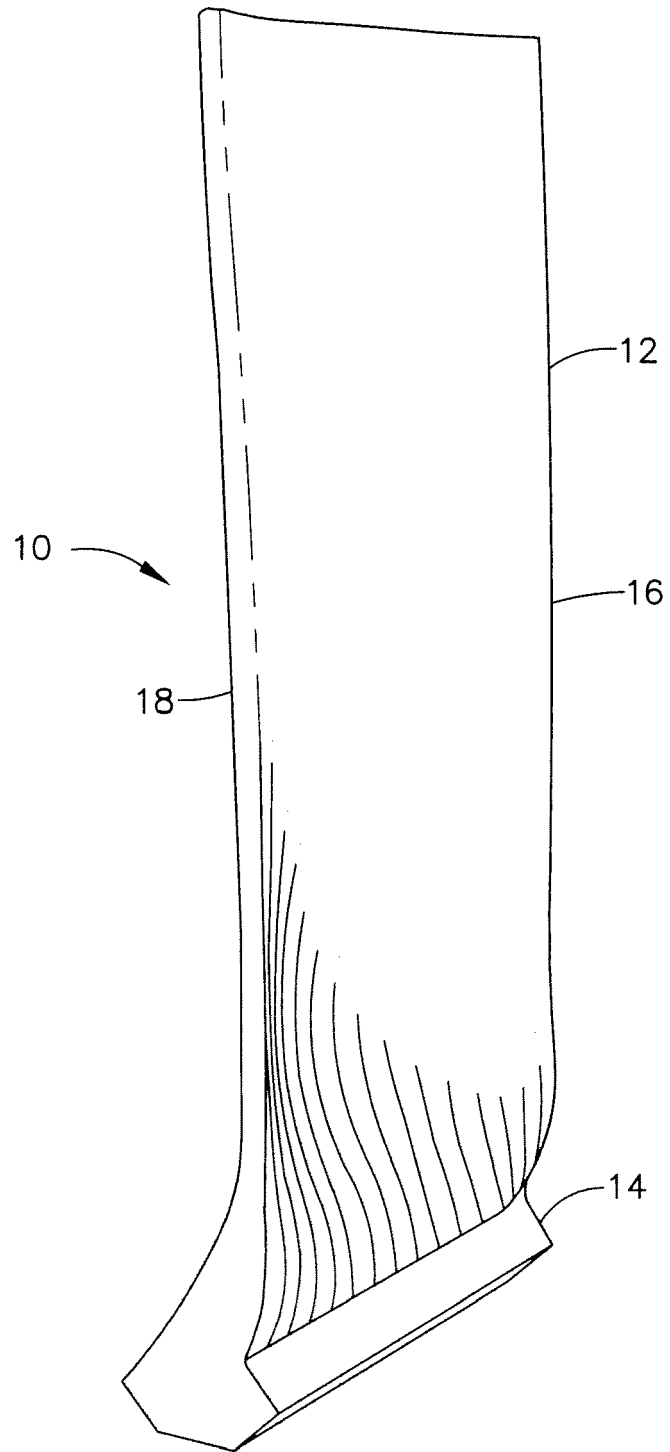

FIG. 1

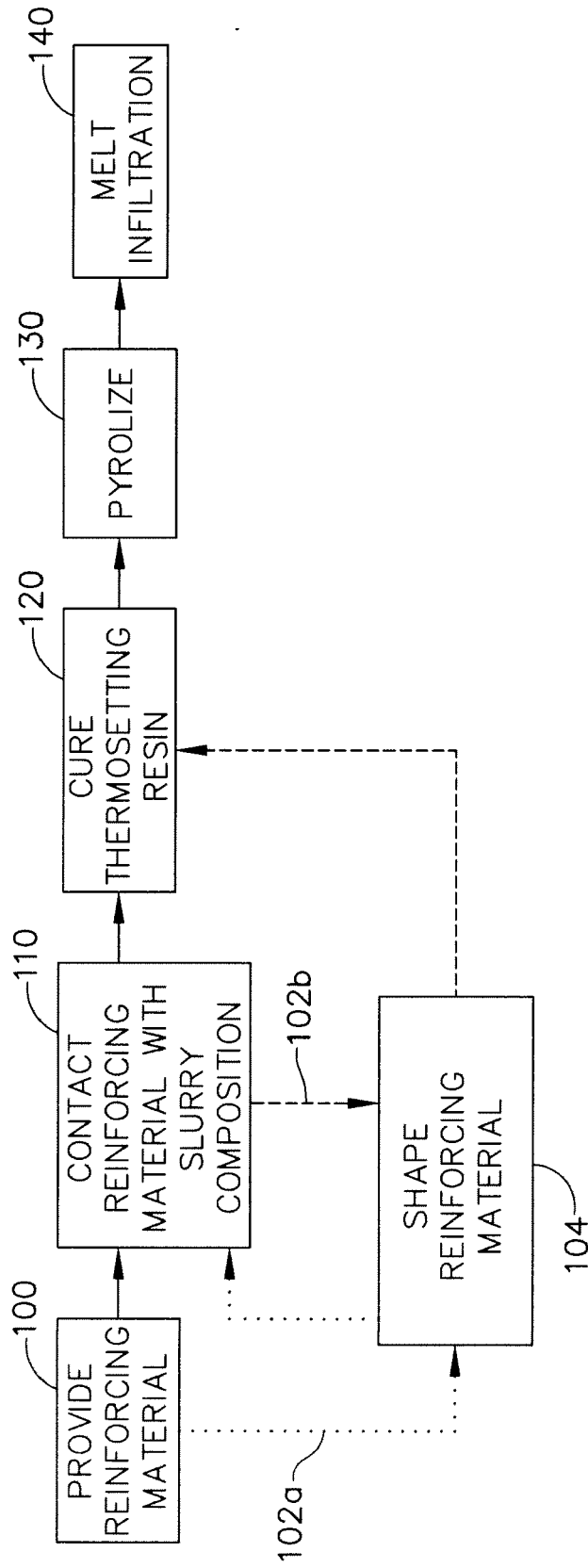

FIG. 2



EUROPEAN SEARCH REPORT

Application Number  
EP 10 19 5942

DOCUMENTS CONSIDERED TO BE RELEVANT				
Category	Citation of document with indication, where appropriate, of relevant passages	Relevant to claim	CLASSIFICATION OF THE APPLICATION (IPC)	
X	US 6 024 898 A (STEIBEL JAMES D [US] ET AL) 15 February 2000 (2000-02-15) * claims 1-19; examples A-D *	1-10	INV. C08K3/00	
X	EP 1 748 036 A1 (TOYOTA MOTOR CO LTD [JP]) 31 January 2007 (2007-01-31) * claims 1-18; example 1 *	1-10		
X	EP 1 524 253 A1 (FRAUNHOFER GES ZURFOERDERUNG D [DE]; TECNARO GES ZUR IND ANWENDUNG [DE]) 20 April 2005 (2005-04-20) * claims 1-32; examples 1-3 *	1-10		
X	WO 02/090291 A1 (MORGAN CRUCIBLE CO [GB]; SPACIE CHRISTOPHER JOHN [GB]; DAVIES ANTHONY) 14 November 2002 (2002-11-14) * claims 1-61; examples 1,2 *	1-10		
X	WO 01/81270 A2 (FREUNDORFER FENSTERBAU [DE]; FREUNDORFER RUDOLF [DE]) 1 November 2001 (2001-11-01) * claims 1-10; example 1 *	1-10		TECHNICAL FIELDS SEARCHED (IPC)
X	EP 1 215 183 A1 (UNITED TECHNOLOGIES CORP [US]) 19 June 2002 (2002-06-19) * claims 1-32; examples 1,2 *	1-10		C08K
X	WO 00/56811 A1 (UNIV MELBOURNE [AU]; QIAO GREG GUANGHUA [AU]; SOLOMON DAVID HENRY [AU]) 28 September 2000 (2000-09-28) * claims 1-52; examples 1-8 *	1-10		
X	WO 99/41440 A1 (UNIV CALIFORNIA [US]; ZHU YUNTIAN T [US]; VALDEZ JAMES A [US]; SHI NIN) 19 August 1999 (1999-08-19) * claims 1-16; examples 1-3 *	1-10		
		-/--		
The present search report has been drawn up for all claims				
Place of search Munich		Date of completion of the search 8 February 2011	Examiner Glomm, Bernhard	
CATEGORY OF CITED DOCUMENTS X : particularly relevant if taken alone Y : particularly relevant if combined with another document of the same category A : technological background O : non-written disclosure P : intermediate document		T : theory or principle underlying the invention E : earlier patent document, but published on, or after the filing date D : document cited in the application L : document cited for other reasons ..... & : member of the same patent family, corresponding document		

1  
EPO FORM 1503 03.82 (P04C01)





EUROPEAN SEARCH REPORT

Application Number  
EP 10 19 5942

DOCUMENTS CONSIDERED TO BE RELEVANT			
Category	Citation of document with indication, where appropriate, of relevant passages	Relevant to claim	CLASSIFICATION OF THE APPLICATION (IPC)
X	EP 0 933 343 A1 (DOW CORNING [US] COI CERAMICS INC [US]) 4 August 1999 (1999-08-04) * claims 1-18; examples 1,2 * -----	1-10	
			TECHNICAL FIELDS SEARCHED (IPC)
The present search report has been drawn up for all claims			
Place of search Munich		Date of completion of the search 8 February 2011	Examiner Glomm, Bernhard
<b>CATEGORY OF CITED DOCUMENTS</b> X : particularly relevant if taken alone Y : particularly relevant if combined with another document of the same category A : technological background O : non-written disclosure P : intermediate document		T : theory or principle underlying the invention E : earlier patent document, but published on, or after the filing date D : document cited in the application L : document cited for other reasons ..... & : member of the same patent family, corresponding document	

1  
EPO FORM 1503 03.82 (P04C01)

ANNEX TO THE EUROPEAN SEARCH REPORT  
ON EUROPEAN PATENT APPLICATION NO.

EP 10 19 5942

This annex lists the patent family members relating to the patent documents cited in the above-mentioned European search report. The members are as contained in the European Patent Office EDP file on  
The European Patent Office is in no way liable for these particulars which are merely given for the purpose of information.

08-02-2011

Patent document cited in search report		Publication date	Patent family member(s)	Publication date
US 6024898	A	15-02-2000	US 6258737 B1	10-07-2001
EP 1748036	A1	31-01-2007	CN 1946655 A	11-04-2007
			EP 2216310 A1	11-08-2010
			JP 2005306688 A	04-11-2005
			WO 2005102961 A1	03-11-2005
			KR 20070012494 A	25-01-2007
			US 2007166546 A1	19-07-2007
			US 2010292069 A1	18-11-2010
EP 1524253	A1	20-04-2005	AT 365150 T	15-07-2007
			DE 10347701 A1	19-05-2005
			WO 2005037733 A1	28-04-2005
WO 02090291	A1	14-11-2002	CA 2444806 A1	14-11-2002
			CN 1524066 A	25-08-2004
			EP 1385802 A1	04-02-2004
			GB 2375501 A	20-11-2002
			JP 2004527444 T	09-09-2004
			MX PA03009888 A	17-02-2004
			US 2004131533 A1	08-07-2004
WO 0181270	A2	01-11-2001	AU 7049601 A	07-11-2001
			DE 10020655 A1	08-11-2001
EP 1215183	A1	19-06-2002	JP 2002234777 A	23-08-2002
			US 2002076541 A1	20-06-2002
WO 0056811	A1	28-09-2000	AU 775602 B2	05-08-2004
			CA 2367157 A1	28-09-2000
			EP 1210387 A1	05-06-2002
			NO 20014604 A	08-11-2001
			US 6958370 B1	25-10-2005
			ZA 200107808 A	03-05-2002
WO 9941440	A1	19-08-1999	AU 2764199 A	30-08-1999
EP 0933343	A1	04-08-1999	DE 69908990 D1	31-07-2003
			DE 69908990 T2	19-05-2004
			JP 11269768 A	05-10-1999
			US 6251520 B1	26-06-2001

**REFERENCES CITED IN THE DESCRIPTION**

*This list of references cited by the applicant is for the reader's convenience only. It does not form part of the European patent document. Even though great care has been taken in compiling the references, errors or omissions cannot be excluded and the EPO disclaims all liability in this regard.*

**Patent documents cited in the description**

- US 5015540 A [0005]
- US 5330854 A [0005]
- US 5336550 A [0005]
- US 6258737 B [0006]
- US 4737328 A [0017]