



(11) **EP 2 425 949 A1**

(12) **EUROPEAN PATENT APPLICATION**

(43) Date of publication:
07.03.2012 Bulletin 2012/10

(51) Int Cl.:
B28B 7/02 (2006.01)

(21) Application number: **11176822.2**

(22) Date of filing: **08.08.2011**

(84) Designated Contracting States:
**AL AT BE BG CH CY CZ DE DK EE ES FI FR GB
GR HR HU IE IS IT LI LT LU LV MC MK MT NL NO
PL PT RO RS SE SI SK SM TR**
Designated Extension States:
BA ME

(71) Applicant: **Beheermaatschappij De Boer Nijmegen
B.V.**
6604 LL Wijchen (NL)

(72) Inventor: **Kosman, Wilhelmus Jacobus Maria**
6562 DA GROESBEEK (NL)

(30) Priority: **11.08.2010 NL 2005213**

(74) Representative: **Haan, Raimond**
Arnold & Siedsma
Sweelinckplein 1
2517 GK Den Haag (NL)

(54) **A mould container pressing device provided with a support device, and such a support device and method for manufacture thereof**

(57) The present invention relates to a mould container pressing device for manufacturing green bricks from clay for the brick manufacturing industry, comprising a support device, the support device comprising a substantially elongate base plate part and a substantially elongate first step plate part, wherein both plate parts comprise an upper side, an underside, end surfaces, a front side and a rear side, wherein the first step plate part

comprises a plate thickness and is provided at regular distances with recesses, wherein the first step plate part is arranged with its underside against the upper side of the base plate part, and wherein the upper sides of the base plate part and the first step plate part together form a stepped support surface on which the bases displaceable in the mould containers can be supported.

The invention further relates to such a support device and a method for manufacture thereof.

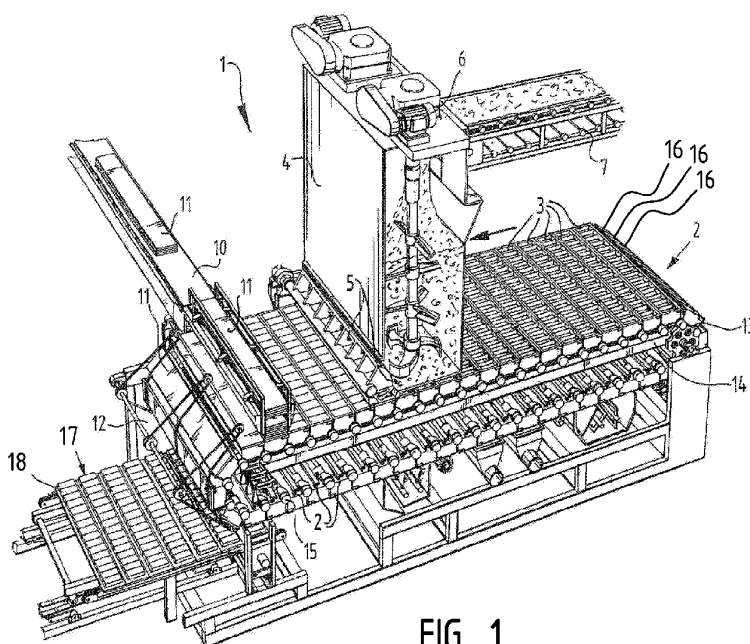

FIG. 1

EP 2 425 949 A1

Description

[0001] The present invention relates to a mould container pressing device provided with a support device, such a support device and a method for manufacture thereof.

[0002] The invention relates more particularly to a mould container pressing device for manufacturing green bricks from clay for the brick manufacturing industry, comprising:

- a circulating conveyor formed from connected mould conveyor parts, wherein each mould conveyor part comprises one or more mould containers, each with a mould cavity;
- at least one ejecting device which is arranged on the conveyor and movable relative to the conveyor and which is adapted to eject a green brick present in the mould container during a release stage;
- wherein the ejecting device comprises at least one base which is displaceable in the mould container and which supports during the molding stage against a stepped support device, wherein using an adjustable support height the height of the green brick to be formed in the mould container can be adjusted via the depth of the mould container. Such a mould container pressing device is also known from EP-A 1 595 665 of applicant.

[0003] Bricks can be supplied in different height dimensions. A frequently applied type of brick is the 'Waal' brick variety size with a height of 50 mm. Brick varieties with differing heights can however also be supplied, such as the 'Vecht' variety, 40 mm in height, the 'Renova' variety, 55 mm in height and the 'Thick Waal' variety, 65 mm in height. Extreme height dimensions can be found in the 'Lilliput II' variety with a height of 30 mm and the 'Kloostermop' variety with a height of 85 mm. Paving bricks can be supplied with a height of 100 mm.

[0004] When a change is made in brick variety during the production process, the height of the brick has to be adapted. The height of the green brick to be formed has to be modified for this purpose in the production process of a mould container press.

[0005] A mould container press consists of a circulating conveyor formed from connected mould conveyor parts, wherein each mould conveyor part comprises one or more mould containers, each with a mould cavity. A typical mould container press consists of about 50 mould conveyor parts, with 24 mould containers, each with a mould cavity, per mould container part.

[0006] Arranged in each mould container part are ejectors for pressing out of the respective mould container the green bricks formed therein. The depth of the mould cavity of the mould containers is defined in that a base of the ejectors which is movable in the mould container supports against a support body arranged thereunder. The movable base is generally arranged on an ejector,

and is therefore referred to below as ejector base. Each ejector base is provided with legs with which the ejector base supports on one or more support bodies. Using the ejector the green brick formed in the mould container is released in order to be subsequently dried and fired.

[0007] A mould container press consisting of 50 mould container parts with 24-brick mould container parts has no less than 1200 mould containers, each with a mould cavity. In order to avoid every ejector base having to be adjusted separately during a change in the desired brick height, it is usual to arrange per mould container one or more elongated support bodies having a stepped form as seen in side view.

[0008] Through lateral displacement of the support body it is possible to achieve in one operation, for a large number of mutually adjacent ejector bases, that they support on a higher or lower step of the support body.

[0009] Two strips - one for each side of the ejector bases - generally have to be shifted per mould container. In the case of a mould container press consisting of 50 mould container parts, the number of manual operations for adjusting the height dimension of 1200 mould containers is reduced to 2 x 50, or 100 operations. The height dimension of the green bricks to be formed can hereby be adjusted for a whole mould conveyor within 30 minutes working time.

[0010] Currently known support bodies are manufactured by welding block parts to an elongate plate part at fixed mutual distances from each other.

[0011] Known from the GB-A-257,112 is a wedge-like device for adjusting the thickness of green bricks.

[0012] Since each ejector base is provided in all corners with a leg, i.e. four legs per ejector base, a 24-brick mould container part requires that no less than 4 x 24, or 96 block parts - divided over two support bodies - have to be welded.

[0013] For a mould container press consisting of 50 mould container parts, 50 x 96, or 4800 of such block parts have to be welded. That this is hugely labour-intensive and time-consuming becomes even more apparent when one takes into account that each block part is welded with at least two welds, and preferably with four all-round welds. This is a total of at least 9600 welds!

[0014] In addition to the labour-intensive and time-consuming process of welding the large number of block parts, welding has a further significant drawback. This is because the buildup of heat associated with the welding regularly results in curving of the strip part of the support body. If this occurs, a further processing is required.

[0015] The mutual distance between the block parts has to be so precise that, when the support body is shifted, all legs of the ejector bases will support at the same height level. This means that all legs of the ejector bases either support on the plate part or on block parts welded thereon. In short, all 4800 block parts have to be welded at exactly the correct positions to the strip of the support body.

[0016] As a result of curving of the strip it is found in

practice that it is often necessary - once it is mounted on the mould container press - to carry out further manual operations, this being labour-intensive.

[0017] An object of the present invention is to provide a device and method wherein the stated drawbacks do not occur, or at least do so to lesser extent.

[0018] Said object is achieved by providing the mould container pressing device referred to in the preamble for manufacturing green bricks from clay for the brick manufacturing industry with a support device, comprising:

- a substantially elongate base plate part and a substantially elongate first step plate part, wherein both plate parts comprise an upper side, an underside, end surfaces, a front side and a rear side;
- wherein the first step plate part comprises a plate thickness and is provided at regular distances with recesses;
- wherein the first step plate part is arranged with its underside against the upper side of the base plate part; and
- wherein the upper sides of the base plate part and the first step plate part together form a stepped support surface on which the bases displaceable in the mould containers can be supported.

[0019] The recesses extend over the whole plate thickness of the step plate part and thus form a step height corresponding to the plate thickness of the step plate part in which the recesses are arranged. The plate thickness of the step plate part thus determines the step height of the stepped support surface. Plate parts can be supplied in many plate thicknesses. By applying, as base, plate parts with a plate thickness of the desired step height further machining operations in respect of the step height are unnecessary. An accurate step height can hereby be realized in very simple manner.

[0020] Recesses are arranged in the step plate parts, for instance by means of laser cutting technique. Although this can be realized very accurately and efficiently with a CNC machine, it is noted that the accuracy of the cut surfaces of the recesses is of minor importance. This is because only the plate thickness is relevant for and determines the step height.

[0021] The difference between for instance 'Waal' brick variety with a height of 50 mm and 'Thick Waal' variety with a height of 65 mm can be realized in simple manner with a step plate part with a plate thickness of 65 - 50 mm = 15 mm.

[0022] According to a preferred embodiment, the support device further comprises a second step plate part with a plate thickness;

- wherein the second step plate part is provided at regular distances with recesses;
- wherein the second step plate part is arranged with its underside against the upper side of the first step plate part; and

- wherein the upper sides of the base plate part and the step plate parts together form a stepped support surface.

5 **[0023]** A three-step support surface can be realized by applying two step plate parts. In addition to the above-mentioned 'Waal' brick variety and 'Thick Waal' variety with heights of respectively 50 mm and 65 mm, the intermediate 'Renova' variety with a height of 55 mm can
10 for instance also be realized when a first step plate part of 55 - 50 mm = 5 mm is applied and a second step plate part of 65 - 55 mm = 10 mm is applied. The overall maximum step height, which is the sum of the plate thicknesses of the two step plate parts, is once again 5 + 10
15 mm = 15 mm, or the difference between 'Waal' brick variety and 'Thick Waal' variety.

[0024] In order to form a stepped support surface in the assembled state, the recesses in the first and second step plate parts are arranged above each other at least partially, and preferably substantially over the whole length of the shortest recess.

[0025] According to a further preferred embodiment, the recesses in lengthwise direction of the second step plate part are substantially longer than the recesses arranged in lengthwise direction of the first step plate part, so that the upper sides of the base plate part and the step plate parts together form a three-step support surface.

[0026] It is possible to envisage two successive step plate parts comprising substantially the same length of recess, for instance because processing of two thinner plates is simpler. Within the teaching of this patent application such thicker step plate parts assembled from thinner step plate parts must be deemed as one assembled step plate part.

[0027] In addition, it will be apparent to the skilled person that a stepped support surface to be formed does not preclude intermediate step plate parts also being applied, wherein the recesses of these intermediate step plate parts are slightly shorter in lengthwise direction than the recesses arranged in a step plate part lying thereabove, while the recesses of these intermediate step plate parts are also longer than the recesses of a step plate part lying thereunder. Although such an embodiment expressly falls within the scope protection of the invention, it has only a minor preference since in the case of support on the overhanging part of an intermediate step plate part bending of this overhanging part can occur.

[0028] According to yet another preferred embodiment, the support device is provided with one or more further step plate parts, the further step plate parts comprising:

- a plate thickness; and
- 55 - recesses which are arranged at regular distances and which are substantially longer in lengthwise direction of the further step plate part than the recesses arranged in lengthwise direction in a step plate part

lying thereunder, so that the upper sides of the step plate part lying thereunder and the further step plate part together form a stepped support surface.

[0029] In similar manner as described above, additional steps can be realized in the stepped support surface using further step plate parts.

[0030] According to yet another preferred embodiment, the base plate part and the one or more step plate parts have substantially the same length and width dimensions. The one or more step plate parts and the base plate part can hereby be assembled in simple manner to form a plate part package, the plate parts of which can be easily attached to each other.

[0031] The invention further relates to a support device for setting the height of a green brick to be formed and intended for use in a mould container pressing device for manufacturing green bricks from clay for the brick manufacturing industry as described above, the support device comprising:

- a substantially elongate base plate part and a substantially elongate first step plate part, wherein both plate parts comprise an upper side, an underside, end surfaces, a front side and rear side;
- wherein the first step plate part comprises a plate thickness and is provided at regular distances with recesses;
- wherein the first step plate part is arranged with its underside against the upper side of the base plate part; and
- wherein the upper sides of the base plate part and the first step plate part together form a stepped support surface, wherein the step height is determined by the plate thickness of the first step plate part.

[0032] A stop of an injector of a mould container pressing device can support on the stepped support surface. The step height corresponds to the plate thickness of the step plate part which is provided with recesses and arranged on top of the base plate part.

[0033] The invention further relates to a method for manufacturing a support device as described in the foregoing, the method comprising the steps of:

- arranging recesses at regular distances in one or more plate parts.

[0034] According to preferred embodiment of the method, the recesses are cut out with lasers. Although punching can be envisaged for limited plate thicknesses, the recesses are preferably cut out with lasers. Controlled by a CNC machine, this can take place in very precise and automated manner.

[0035] A preferred embodiment of the method further comprises the step of arranging the first step plate part on a base plate part such that the upper sides of the base plate part and the first step plate part together form a

stepped support surface, wherein the step height is determined by the plate thickness of the first step plate part.

[0036] A preferred embodiment of the method further comprises the step of arranging the second step plate part on the first step plate part such that the upper sides of the base plate part and the step plate parts together form a stepped support surface, wherein the step height of the steps is determined by the plate thicknesses of the first and second step plate parts.

[0037] A preferred embodiment of the method further comprises the step of arranging one or more further step plate parts on the second step plate part such that the step plate part with the smallest recess is subsequently arranged in each case on the preceding step plate part such that the upper sides of the base plate part and the step plate parts arranged thereon together form a stepped support surface.

[0038] A preferred embodiment of the method further comprises the step of mutually attaching the base plate part and the one or more step plate parts arranged thereon.

[0039] According to a preferred embodiment of the method, the base plate part and the one or more step plate parts arranged thereon are attached releasably to each other so that one or more step plate parts can be replaced and/or can be exchanged for a step plate part with another plate thickness. A releasable attachment can for instance be realized by making drilled holes in the base plate part and the step plate parts through which a bolt connection can be placed, although other variants can also be envisaged.

[0040] Preferred embodiments of the present invention are further elucidated in the following description with reference to the drawing, in which:

Figure 1 is a perspective view of a device for manufacturing green bricks from clay for the brick manufacturing industry;

Figure 2 is a cut-away side view of a mould container in which is arranged an ejecting device provided with a prior art support device;

Figure 3 is a perspective detail view of the prior art support device shown in figure 2;

Figure 4 is a cut-away side view of a mould container in which is arranged an ejecting device provided with a support device according to the present invention; Figure 5 is a perspective detail view of the support device according to the present invention shown in figure 4; and

Figure 6 is an exploded view of the support device shown in figure 5.

[0041] Figure 1 shows a mould container pressing device 1 for manufacturing green bricks 18 from clay for the brick manufacturing industry, comprising a circulating conveyor 2 formed from connected mould container parts 3, wherein each mould container part 3 comprises one or more mould containers 16, each with a mould cavity

19, a reservoir 4 for clay arranged above mould containers 16, clay arranging means for arranging clay from reservoir 4 in mould containers 16 during a moulding stage, means for covering an open side of mould containers 16 with take-off plates 11, at least one ejecting device 20 arranged on conveyor 2 and movable relative to conveyor 2, wherein ejecting device 20 is adapted to eject a green brick 18 present in mould container 16 onto an associated take-off plate 11 during a release stage, wherein ejecting device 20 comprises at least one base 38 which is displaceable in mould container 16 and which supports during the moulding stage with legs 42 functioning as spacers against a stepped support device 22, wherein using an adjustable support height the height of the green brick 18 to be formed in mould container 16 is adjustable via the depth of mould container 16.

[0042] Device 1 for manufacturing green bricks for the brick manufacturing industry comprises a chain conveyor 2, also referred to as mould conveyor. This chain conveyor 2 is assembled from a large number of mutually connected mould container parts 3, each comprising a number of mould containers 16. In figure 1 the mould container parts 3 are provided in each case with sixteen mould containers 16. Each mould container 16 comprises a mould cavity 19 in which clay can be received for the purpose of forming a green brick 18. Mould container parts 3 are coupled to each other and provided with rollers 15 rotatable over girders 14 so as to together thus form the chain - or conveyor - of chain conveyor 2 - or mould conveyor. The chain is driven by one of the chain wheels 13 or by both chain wheels 13 (wherein for the sake of clarity only the right-hand chain wheel is shown in figure 1). The transporting direction of the chain conveyor is to the left in the shown embodiment of figure 1 (P_1 in figure 1). A conveyor rotating to the right is of course likewise possible.

[0043] Placed above mould containers 16 is a reservoir 4 for clay which is kept in continuous movement by an agitator 5 driven by motor 6. Clay is fed to reservoir 4 by a circulating conveyor 7. The clay is carried out of reservoir 4 into mould container 16 and then pressed down by a pressing device 8 which is pivotable around a shaft 9. The excess clay is also trimmed using means which are not drawn.

[0044] The device 1 further comprises a conveyor 10 with which take-off plates 11 are supplied. Conveyor 10 also ensures that a take-off plate 11 is placed on top of each passing mould container part 3. Take-off plates 11 remain pressed against the respective mould container parts 3 by a holding mechanism 12 when they pass over the left-hand chain wheel (not shown) on the discharge side of the device. After turning over of the mould container part 3, the green bricks 18 still lie on plates 11.

[0045] An ejecting device 20 as shown in figures 2 and 4 presses the green bricks 18 out of mould containers 16 per mould container part 3. Green bricks 18 herein remain lying on plates 11 after they have been released from mould containers 16. Plates 11 with green bricks

18 thereon are then discharged for further treatment, such as drying and firing.

[0046] Figures 2 and 3 show a prior art embodiment. Shown in figure 2 is a mould container 16 in a mould container part 3 in which an ejecting device 20 provided with a prior art support device 22 is arranged. This support device 22, which according to the prior art comprises a plate part 24 with block parts 25 welded thereon, is shown in more detail in figure 3.

[0047] Figure 4 shows a mould container 16 in a mould container part 3 in which an ejecting device 20 provided with a support device 22 to according to the present invention is arranged.

[0048] Mould container part 3 is assembled from different mould containers 16 connected to form a unit. Mould container part 3 further comprises a chain part 44 onto which link parts 46 are welded. When different mould container parts 3 with chain parts 44 are placed adjacently of each other and a shaft 52 is inserted through the link parts, these mould container parts 3 are connected to form a chain conveyor 2. Situated on the end of shaft 52 is a runner 48. A bolt 56 is also provided to lock the shaft 52 through link parts 46.

[0049] Ejecting device 20 is assembled from an ejector base 38 and an ejector shaft 36 which has at least on its side remote from ejector base 38 a stop in the form of cap nut 64. Ejector base 38 is arranged displaceably in mould container 16 of mould container part 3.

[0050] Arranged round ejector shaft 36 is a spring 62 which engages with its outer end 72 on an edge of the cap nut 64 screwed onto an outer end of ejector shaft 36 provided with screw thread.

[0051] Support device 22 can be clamped releasably using a bolt 56, which is biased with a compression spring 58 against lower wall 54 of mould container part 3. By temporarily releasing the clamping the support device 22 is displaceable in lengthwise direction of mould container part 3 so that the stops 42 located on the underside of ejector base 38 support as desired on a selected step of the stepped support surface of support device 22. Stops 42 function here as spacer and thus determine the depth of the mould cavity 19 in which a green brick 18 is formed.

[0052] Support device 22 is shown in more detail in figures 5 and 6, and comprises a substantially elongate base plate part 24 and a substantially elongate first step plate part 26, wherein both plate parts 24, 26 comprise an upper side B, an underside O, end surfaces K, a front side V and a rear side A, wherein the first step plate part 26 comprises a plate thickness D^{26} and is provided at regular distances with recesses U^{26} , wherein the first step plate part 26 is arranged with its underside O^{26} against the upper side B^{24} of base plate part 24, and wherein the upper sides B^{24} , B^{26} of base plate part 24 and the first step plate part 26 together form a stepped support surface on which the bases 38 displaceable in mould containers 16 can be supported.

[0053] A step plate part 28 is also provided with a plate thickness D^{28} which is provided at regular distances with

recesses U^{28} which are substantially longer in lengthwise direction of the second step plate part 28 than the recesses U^{26} arranged in lengthwise direction of the first step plate part 26.

[0054] The second step plate part 28 is arranged with its underside O^{28} against the upper side B^{26} of the first step plate part 26, whereby the upper sides B^{24} , B^{26} , B^{28} of base plate part 24 and the step plate parts 26, 28 together form a three-step support surface.

[0055] The exploded view of figure 6 shows how recesses U^{26} and U^{28} in respectively the first and second step plate parts are arranged one above the other at least partially, and preferably substantially over the whole length of the shortest recess, in this case U^{26} . A stepped support surface is hereby formed in the assembled situation of plate parts 24, 26, 28.

[0056] With a thickness D^{26} of the first step plate part 26 of 5 mm and a thickness D^{28} of the second step plate part 28 of 10 mm bricks in 'Waal' variety, 'Renova' variety and 'Thick Waal' variety, with respective brick heights of 50 mm, 55 mm and 65 mm, can be realized with the embodiment shown in figures 5 and 6.

[0057] By selecting other plate thicknesses corresponding to the height difference between different varieties of brick the skilled person can modify the brick height as desired to the brick height to be manufactured.

[0058] Of particular interest are step plate parts with plate thicknesses of 5, 10, 15, 20, 25, 30, 35, 40, 45, 50, 55, 60, 65 and 70 mm, since all varieties of brick referred to in the introduction, from the 'Lilliput II' variety with a brick height of 30 mm to a paving brick with a brick height of 100 mm, can hereby be realized.

[0059] Although they show preferred embodiments of the invention, the above described embodiments are intended only for the purpose of illustrating the present invention and not to limit the scope of the invention in any way. The scope of the invention is therefore defined solely by the following claims.

Claims

1. Support device (22) for adjusting the height of a green brick to be formed, **characterized by:**

- a substantially elongate base plate part (24) and a substantially elongate first step plate part (26), wherein both plate parts (24, 26) comprise an upper side (B), an underside (O), end surfaces (K), a front side (V) and a rear side (A);
- wherein the first step plate part (26) comprises a plate thickness (D^{26}) and is provided at regular distances with recesses (U^{26});
- wherein the first step plate part (26) is arranged with its underside (O^{26}) against the upper side (B^{24}) of the base plate part (24); and
- wherein the upper sides (B^{24} , B^{26}) of the base plate part (24) and the first step plate part (26)

together form a stepped support surface, wherein the step height is determined by the plate thickness (D^{26}) of the first step plate part (26).

2. Support device as claimed in claim 1, further comprising:

- a second step plate part (28) with a plate thickness (D^{28});
- wherein the second step plate part (28) is provided at regular distances with recesses (U^{28});
- wherein the second step plate part (28) is arranged with its underside (O^{28}) against the upper side (B^{26}) of the first step plate part (26); and
- wherein the upper sides (B^{24} , B^{26} , B^{28}) of the base plate part (24) and the step plate parts (26, 28) together form a stepped support surface, wherein the step height of the steps is determined by the plate thicknesses (D^{26} , D^{28}) of the first and second step plate parts (26, 28).

3. Support device as claimed in claim 2, wherein the recesses (U^{28}) in lengthwise direction of the second step plate part (28) are substantially longer than the recesses (U^{26}) arranged in lengthwise direction of the first step plate part (26), so that the upper sides (B^{24} , B^{26} , B^{28}) of the base plate part (24) and the step plate parts (26, 28) together form a three-step support surface.

4. Support device as claimed in claim 2 or 3, wherein the support device (22) is provided with one or more further step plate parts, the further step plate parts comprising:

- a plate thickness; and
- recesses which are arranged at regular distances and which are substantially longer in lengthwise direction of the further step plate part than the recesses arranged in lengthwise direction in a step plate part lying thereunder, so that the upper sides of the step plate part lying thereunder and the further step plate part together form a stepped support surface.

5. Support device as claimed in any of the claims 6-9, wherein the base plate part (24) and the one or more step plate parts (26, 28) have substantially the same length and width dimensions.

6. Mould container pressing device (1) for manufacturing green bricks (18) from clay for the brick manufacturing industry, comprising:

- a circulating conveyor (2) formed from connected mould conveyor parts (3), wherein each mould conveyor part (3) comprises one or more mould containers (16), each with a mould cavity

(19);

- at least one ejecting device (20) which is arranged on the conveyor (2) and movable relative to the conveyor (2) and which is adapted to eject a green brick (18) present in the mould container (16) during a release stage;

- wherein the ejecting device (20) comprises at least one base (38) which is displaceable in the mould container (16) and which supports during the molding stage against a stepped support device (22), wherein using an adjustable support height the height of the green brick (18) to be formed in the mould container (16) can be adjusted via the depth of the mould container (16); **characterized in that** the mould container pressing device (1) comprises a support device as claimed in any of the claims 1-5.

7. Mould container pressing device as claimed in claim 6, wherein the base plate part (24) and the one or more step plate parts (26, 28) have substantially the same length and width dimensions.

8. Method for manufacturing a support device (22) as described in one or more of the claims 1-5, **characterized in that** it comprises the step of:

- arranging recesses (U) at regular distances in one or more plate parts (26, 28).

9. Method as claimed in claim 8, wherein the recesses are cut out with lasers.

10. Method as claimed in claims 8-9, further comprising the step of:

- arranging the first step plate part (26) on a base plate part (24) such that the upper sides (B^{24} , B^{26}) of the base plate part (24) and the first step plate part (26) together form a stepped support surface, wherein the step height is determined by the plate thickness (D^{26}) of the first step plate part (26).

11. Method as claimed in claim 10, further comprising the step of:

- arranging the second step plate part (28) on the first step plate part (26) such that the upper sides (B^{24} , B^{26} , B^{28}) of the base plate part (24) and the step plate parts (26, 28) together form a stepped support surface, wherein the step height of the steps is determined by the plate thicknesses (D^{26} , D^{28}) of the first and second step plate parts (26, 28).

12. Method as claimed in claim 11, further comprising the step of:

- arranging one or more further step plate parts on the second step plate part (28) such that the step plate part with the smallest recess is subsequently arranged in each case on the preceding step plate part such that the upper sides of the base plate part (24) and the step plate parts arranged thereon together form a stepped support surface.

13. Method as claimed in any of the claims 8-12, further comprising the step of:

- mutually attaching the base plate part and the one or more step plate parts arranged thereon.

14. Method as claimed in claim 13, wherein the base plate part and the one or more step plate parts arranged thereon are attached releasably to each other so that one or more step plate parts can be replaced and/or can be exchanged for a step plate part with another plate thickness.

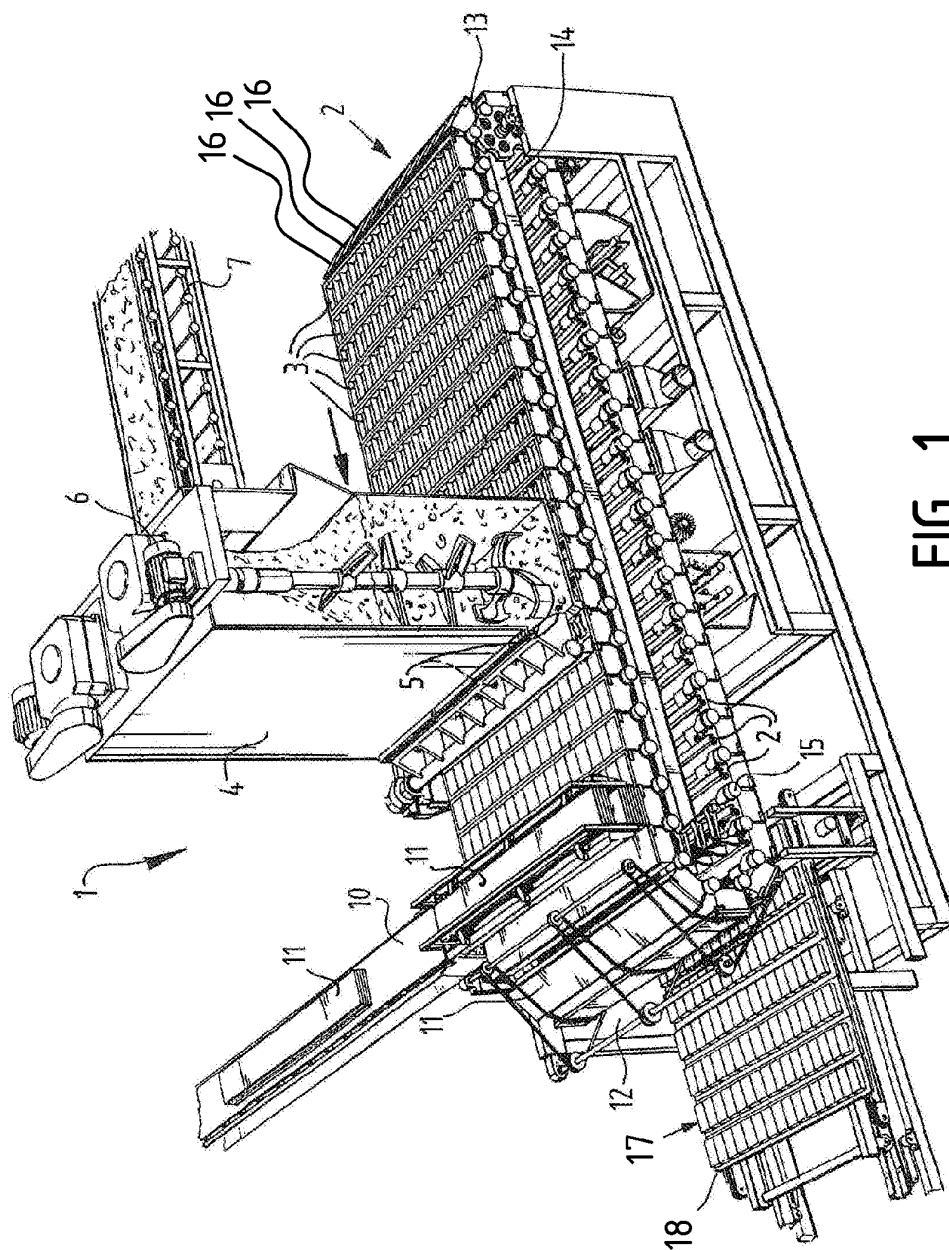

FIG. 1

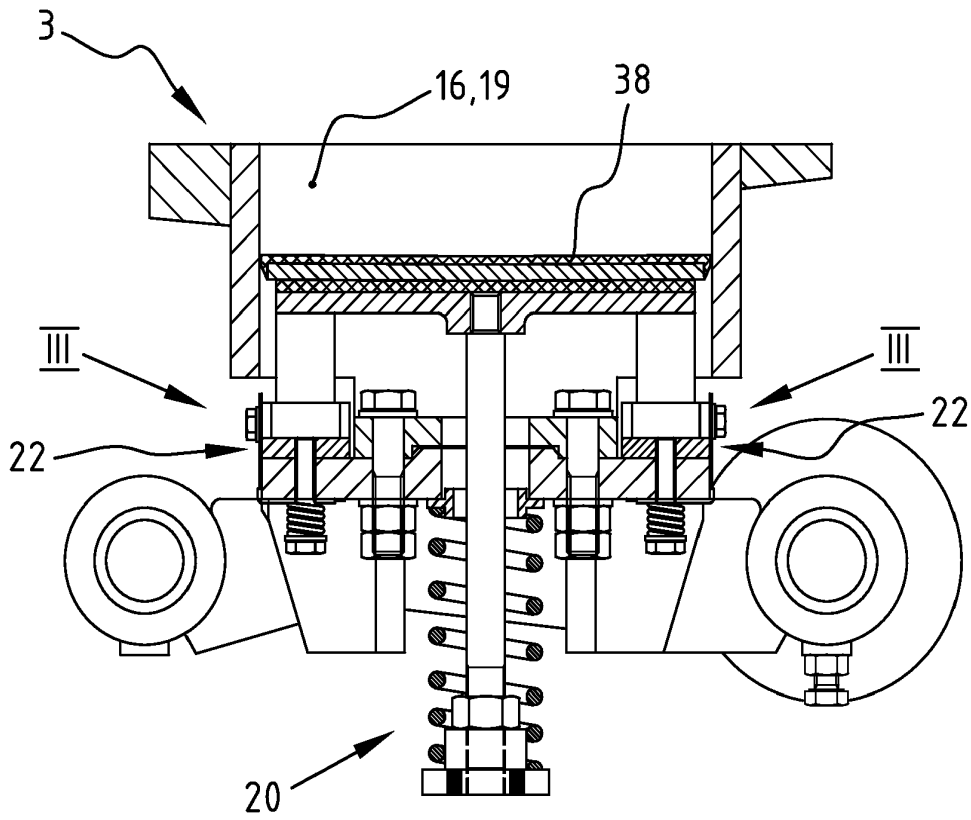

FIG. 2

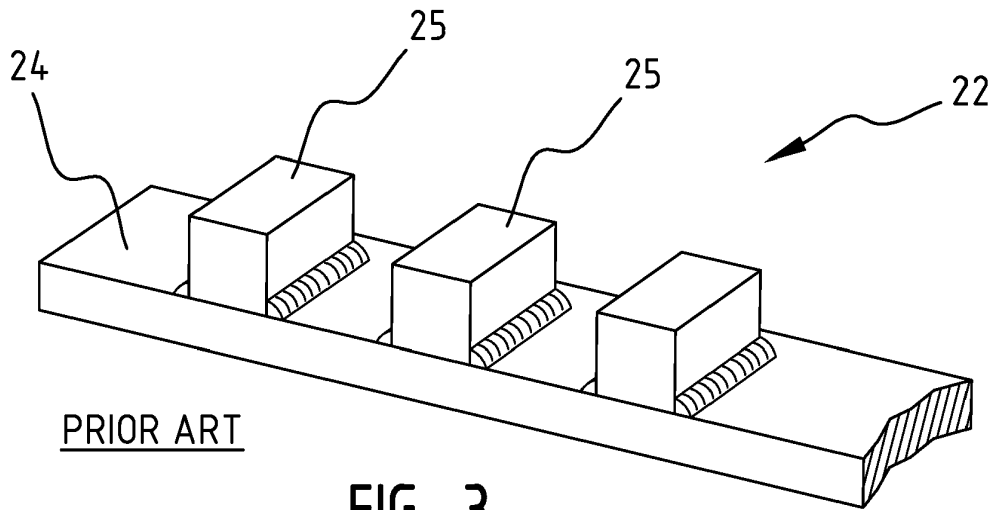
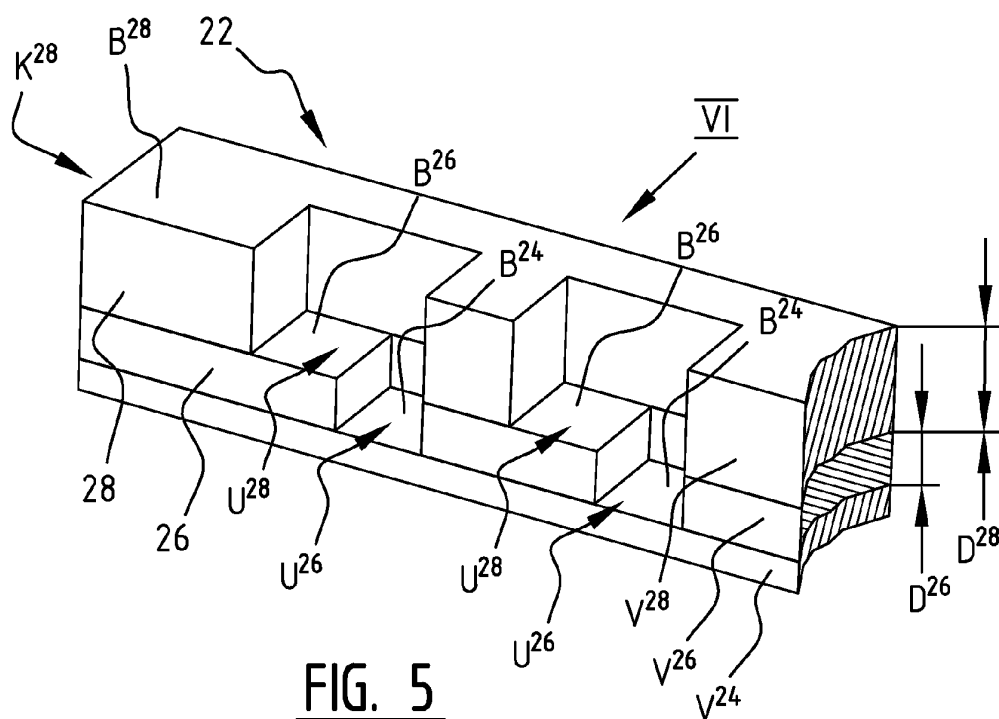
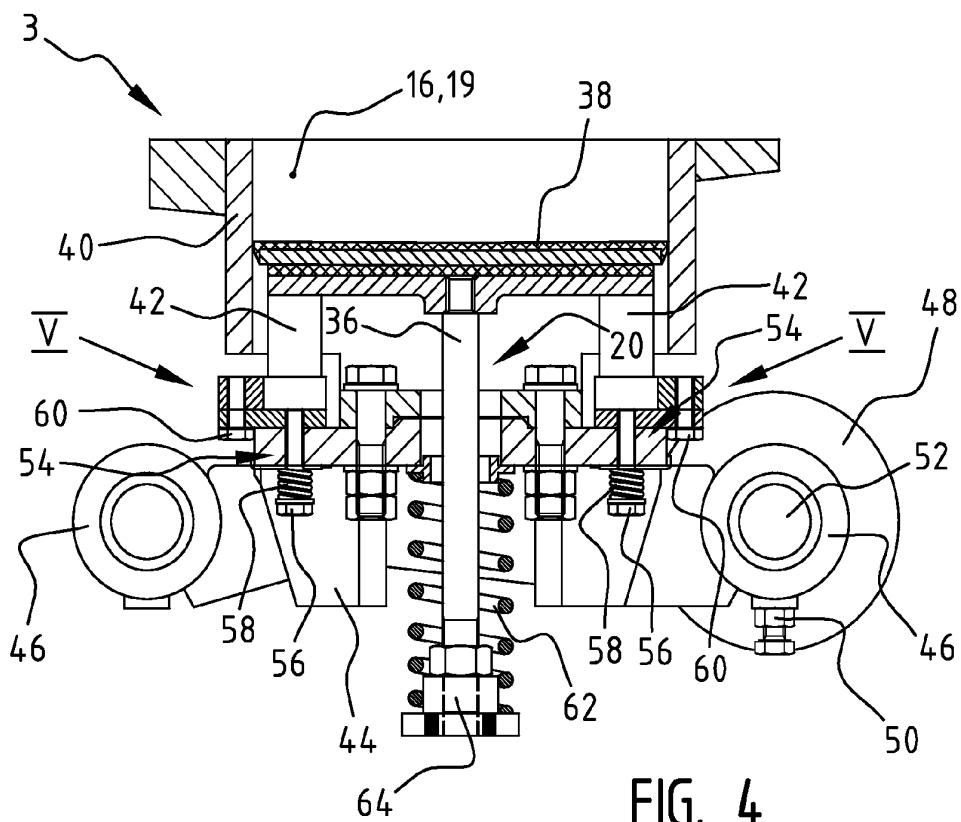

FIG. 3



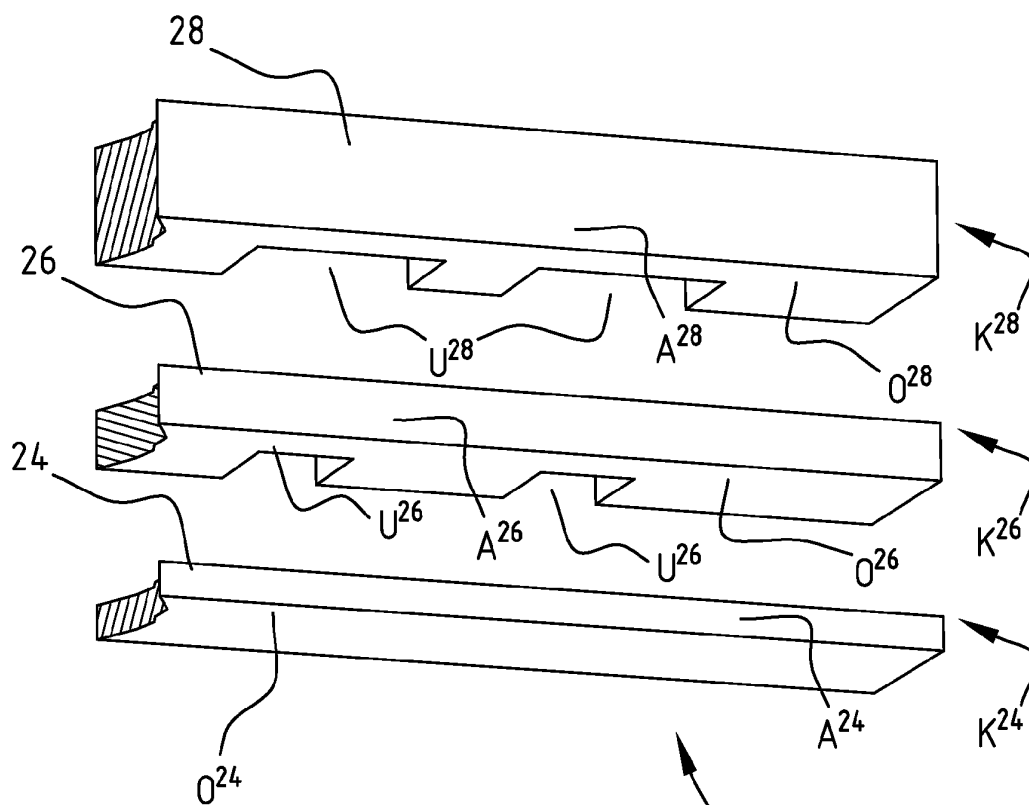

FIG. 6



EUROPEAN SEARCH REPORT

Application Number
EP 11 17 6822

DOCUMENTS CONSIDERED TO BE RELEVANT			
Category	Citation of document with indication, where appropriate, of relevant passages	Relevant to claim	CLASSIFICATION OF THE APPLICATION (IPC)
A	EP 1 595 665 A1 (BEHEERMIJ DE BOER NIJMEGEN B V [NL]) 16 November 2005 (2005-11-16) * paragraph [0028]; figure 4 * -----	1,8	INV. B28B7/02
A	GB 257 112 A (WHITTAKER AND COMPANY LTD C; NORMAN WHITTAKER) 26 August 1926 (1926-08-26) * claims 1-4; figures 2,3 * -----	1	
A	NL 1 006 041 C2 (STRUYK VERWO GROEP B V [NL]) 19 November 1998 (1998-11-19) * claims 1,2; figure 3 * -----	1,8	
A	DE 22 64 247 A1 (KRUPP GMBH) 11 July 1974 (1974-07-11) * claim 1; figure 1 * -----	1,8	
A	EP 1 088 633 A1 (ANVIL IRON WORKS INC [US]) 4 April 2001 (2001-04-04) * claim 1; figure 10a * -----	1	
A	US 3 079 661 A (LAMB HAROLD W) 5 March 1963 (1963-03-05) * figure 1 * -----	1	
The present search report has been drawn up for all claims			TECHNICAL FIELDS SEARCHED (IPC)
			B28B
Place of search		Date of completion of the search	Examiner
The Hague		5 January 2012	Boone, John
CATEGORY OF CITED DOCUMENTS			
X : particularly relevant if taken alone Y : particularly relevant if combined with another document of the same category A : technological background O : non-written disclosure P : intermediate document		T : theory or principle underlying the invention E : earlier patent document, but published on, or after the filing date D : document cited in the application L : document cited for other reasons & : member of the same patent family, corresponding document	

EPC FORM 1503 03 02 (P04C01)

**ANNEX TO THE EUROPEAN SEARCH REPORT
ON EUROPEAN PATENT APPLICATION NO.**

EP 11 17 6822

This annex lists the patent family members relating to the patent documents cited in the above-mentioned European search report. The members are as contained in the European Patent Office EDP file on The European Patent Office is in no way liable for these particulars which are merely given for the purpose of information.

05-01-2012

Patent document cited in search report	Publication date	Patent family member(s)	Publication date
EP 1595665 A1	16-11-2005	EP 1595665 A1	16-11-2005
		NL 1026193 C2	15-11-2005

GB 257112 A	26-08-1926	NONE	

NL 1006041 C2	19-11-1998	NONE	

DE 2264247 A1	11-07-1974	NONE	

EP 1088633 A1	04-04-2001	NONE	

US 3079661 A	05-03-1963	NONE	

EPO FORM P0458

For more details about this annex : see Official Journal of the European Patent Office, No. 12/82

EP 2 425 949 A1

REFERENCES CITED IN THE DESCRIPTION

This list of references cited by the applicant is for the reader's convenience only. It does not form part of the European patent document. Even though great care has been taken in compiling the references, errors or omissions cannot be excluded and the EPO disclaims all liability in this regard.

Patent documents cited in the description

- EP 1595665 A [0002]
- GB 257112 A [0011]