



US 20120328839A1

(19) **United States**

(12) **Patent Application Publication**

LEE et al.

(10) **Pub. No.: US 2012/0328839 A1**

(43) **Pub. Date: Dec. 27, 2012**

(54) **INSULATION BRICK**

Publication Classification

(76) Inventors: **Yong LEE**, Munster, IN (US); **Jamey COSTINO**, Munster, IN (US); **Jim NORRIS**, Highland, IN (US); **Bernard CHUKWULEBE**, Lansing, IL (US)

(51) **Int. Cl.**
B32B 3/30 (2006.01)
(52) **U.S. Cl.** **428/156**

(21) Appl. No.: **13/602,711**

(57) **ABSTRACT**

(22) Filed: **Sep. 4, 2012**

Presented are an insulation brick and the method of using an insulation brick to create a thermal lining. A set of corrugations are formed into a sidewall of the brick to increase the thermal insulation. A first end of the insulation brick has a convex portion while the second end of the insulation brick has a convex portion. This allows a first insulation brick to mate with another brick in an end to end configuration.

Related U.S. Application Data

(63) Continuation of application No. 12/758,093, filed on Apr. 12, 2010, now Pat. No. 8,257,645.

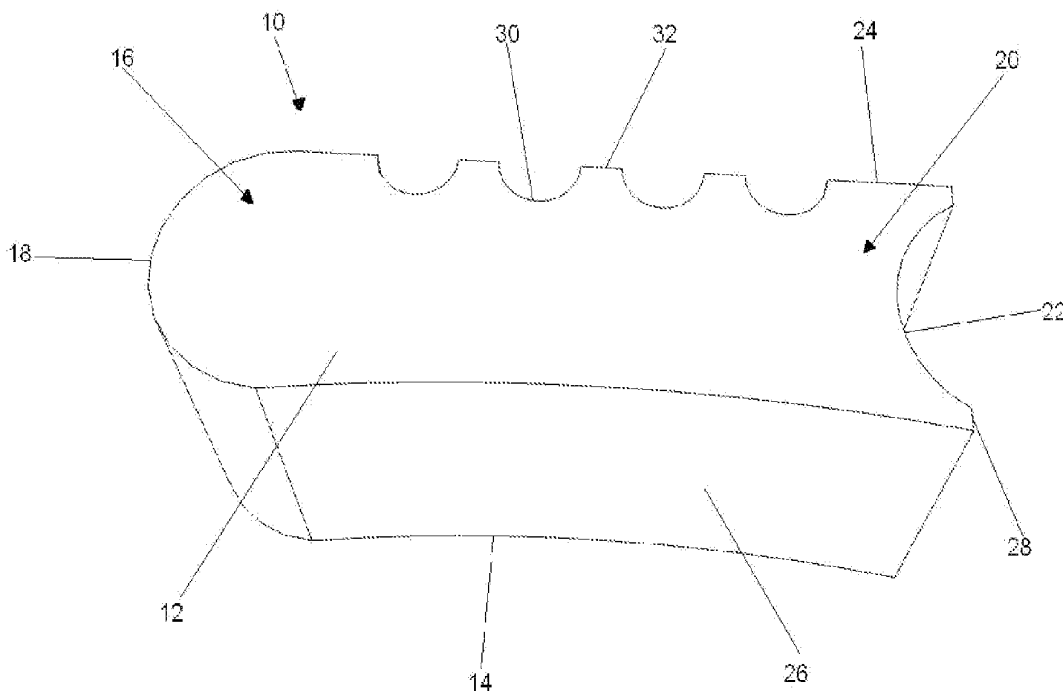

FIGURE 1

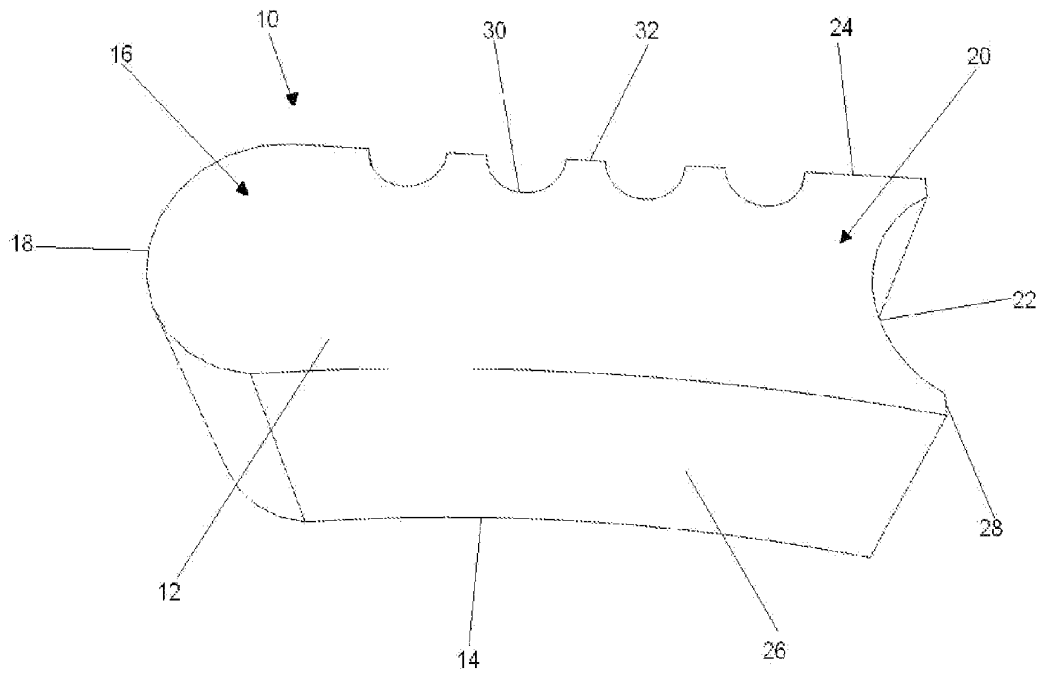

FIGURE 2

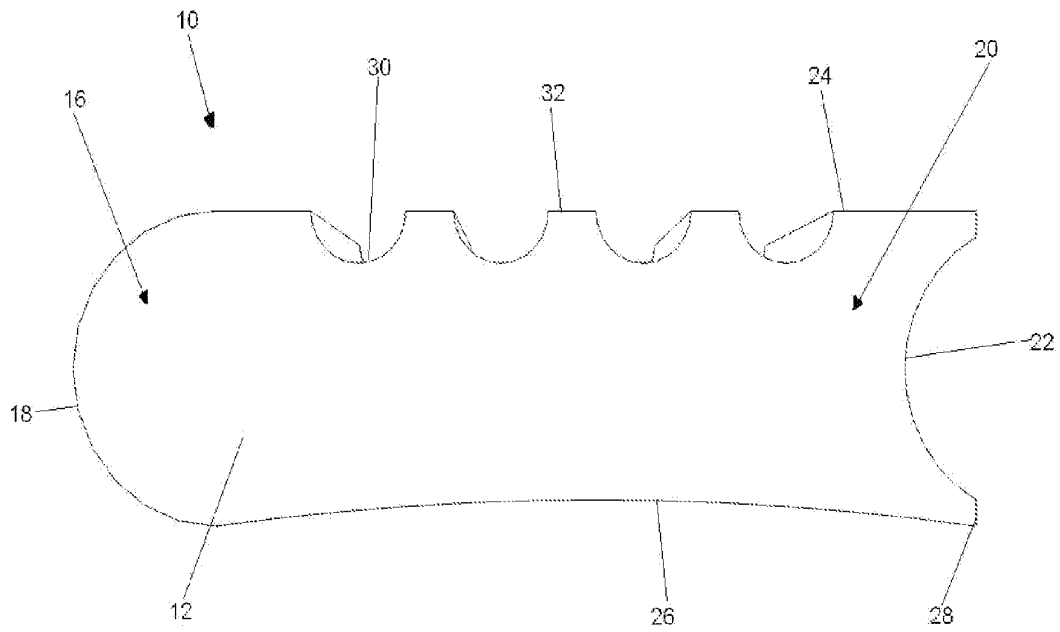

FIGURE 3

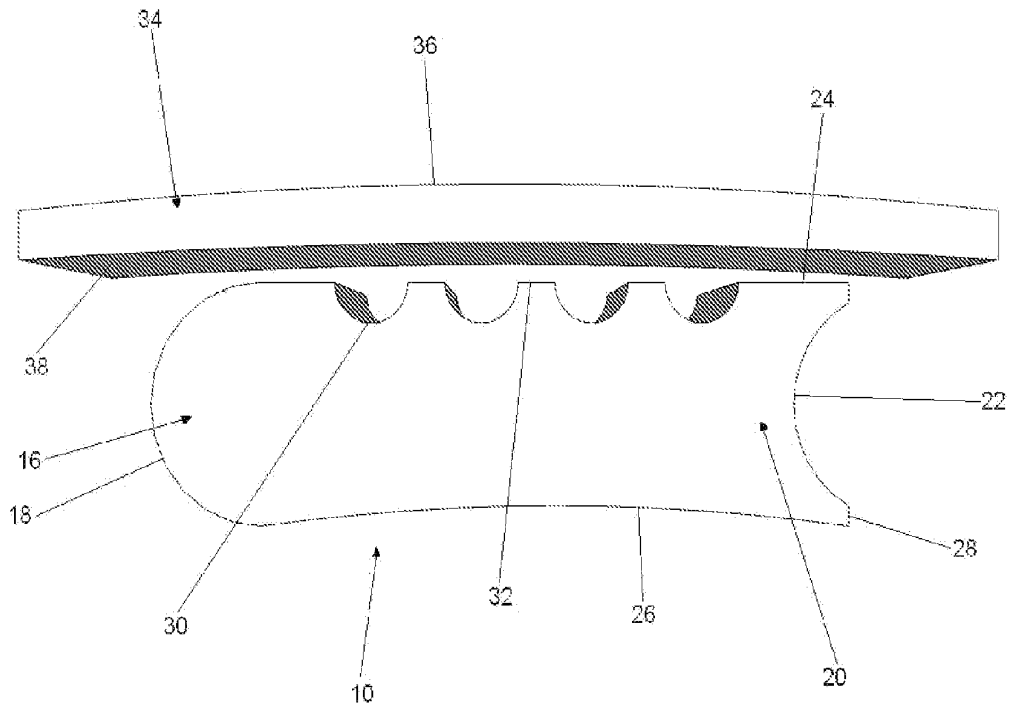

FIGURE 4

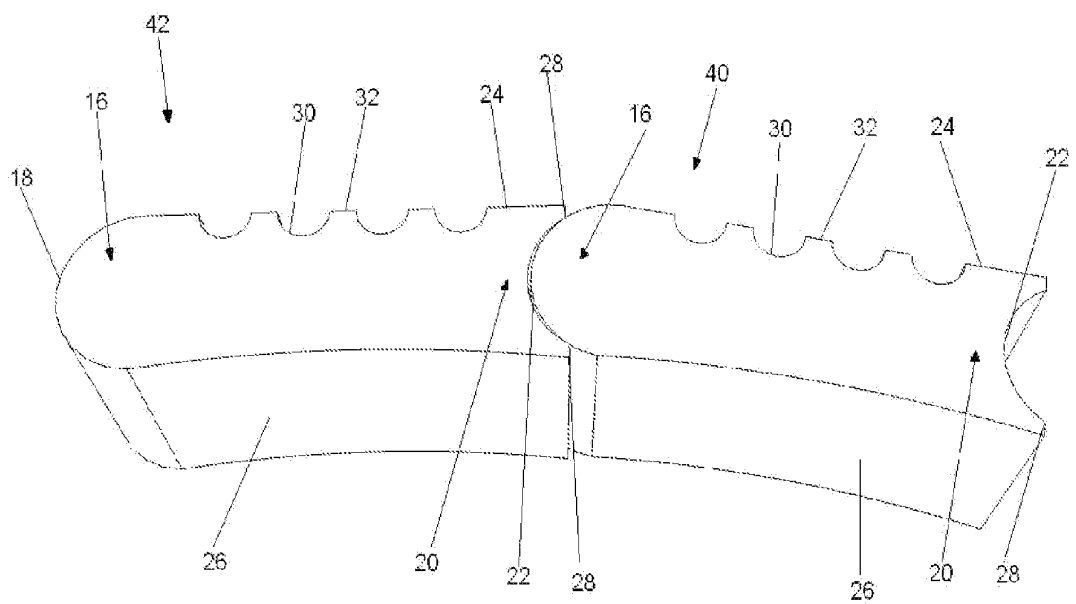

FIGURE 5

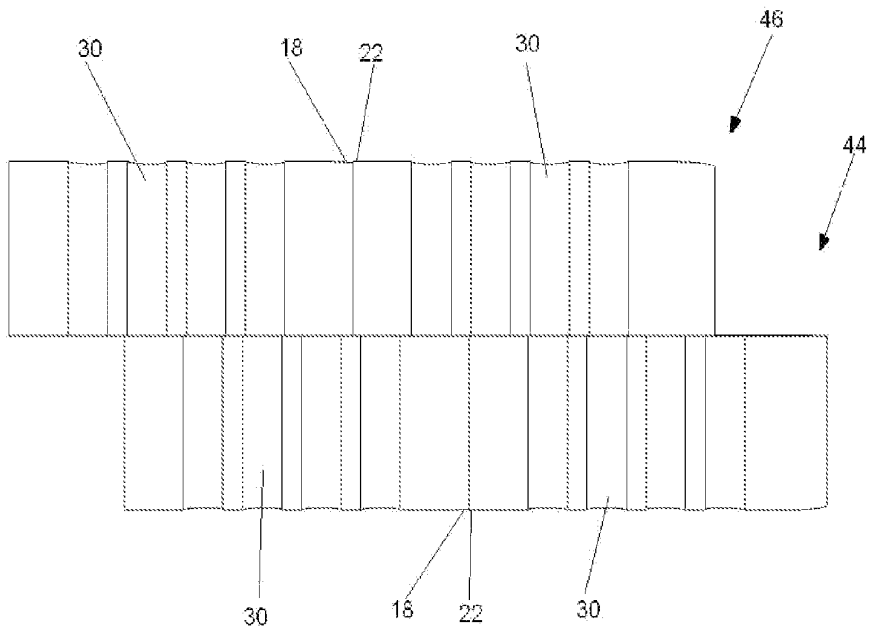

FIGURE 6

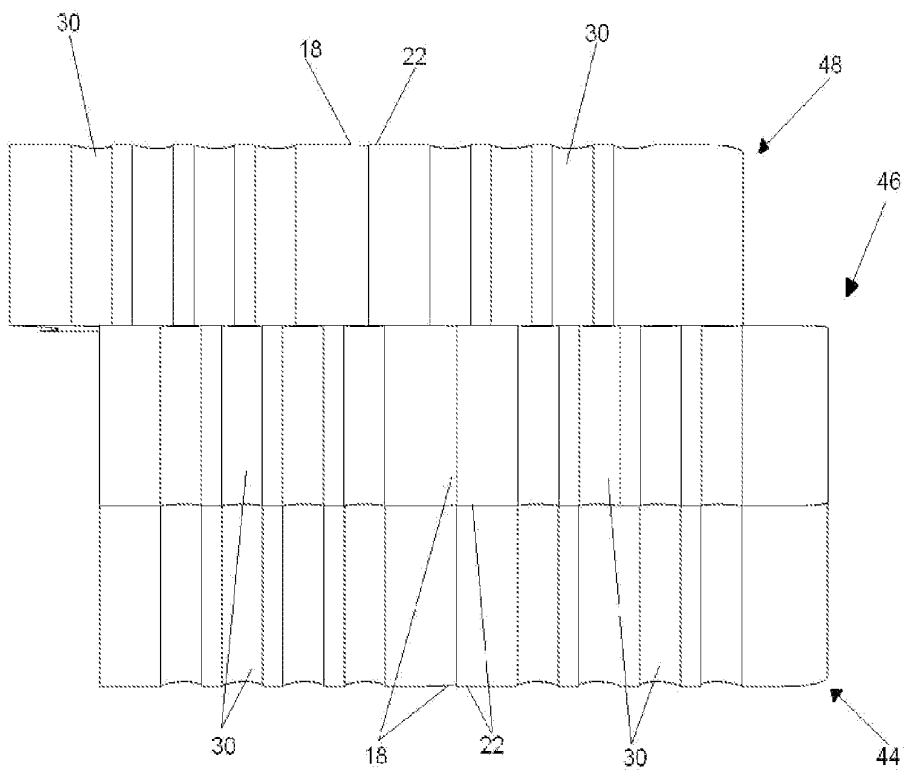

FIGURE 7

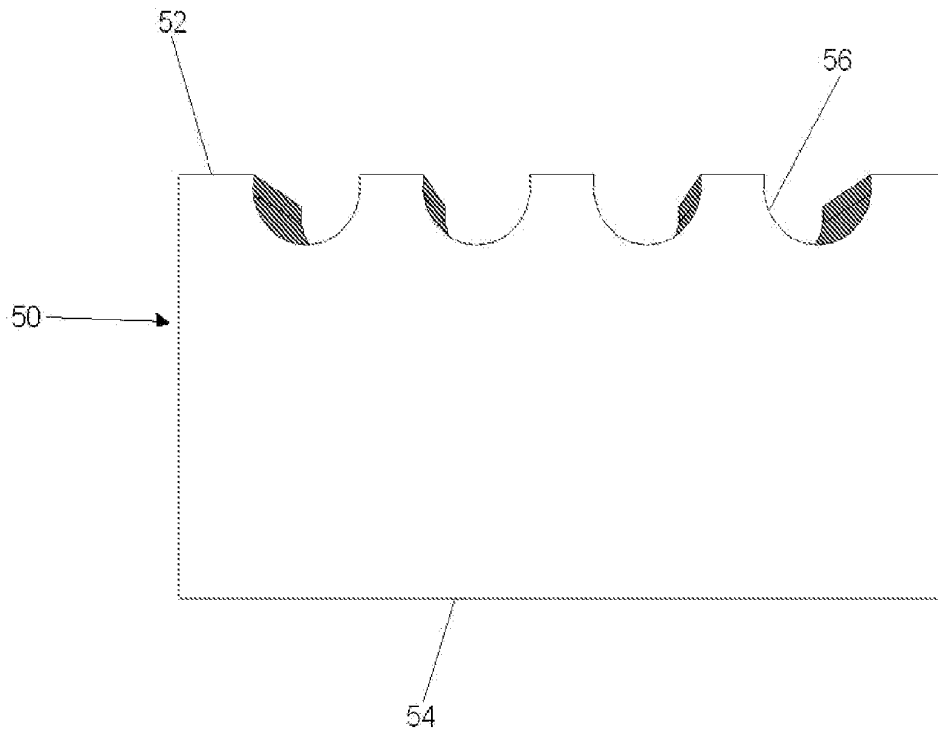

FIGURE 8

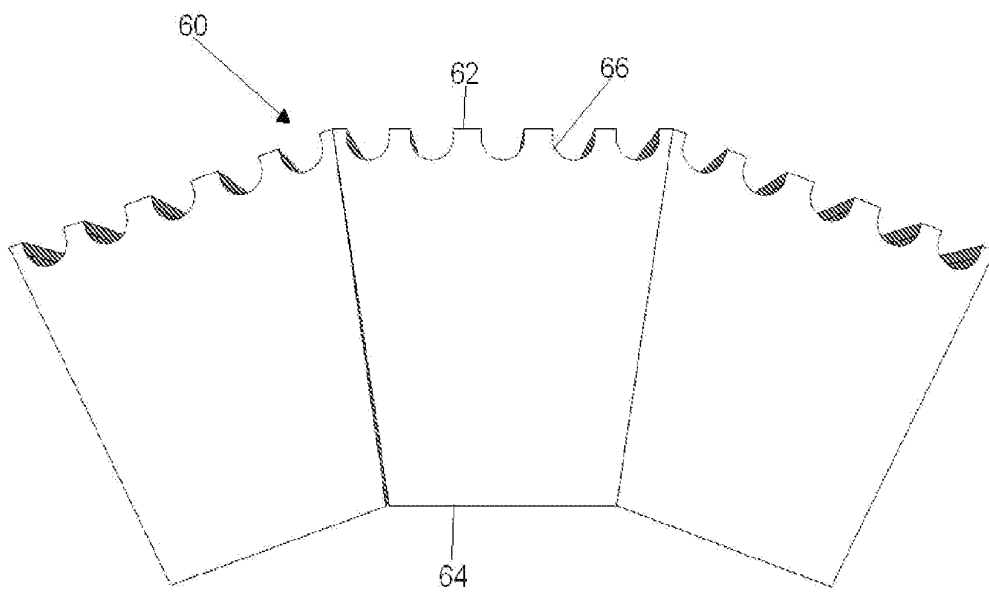
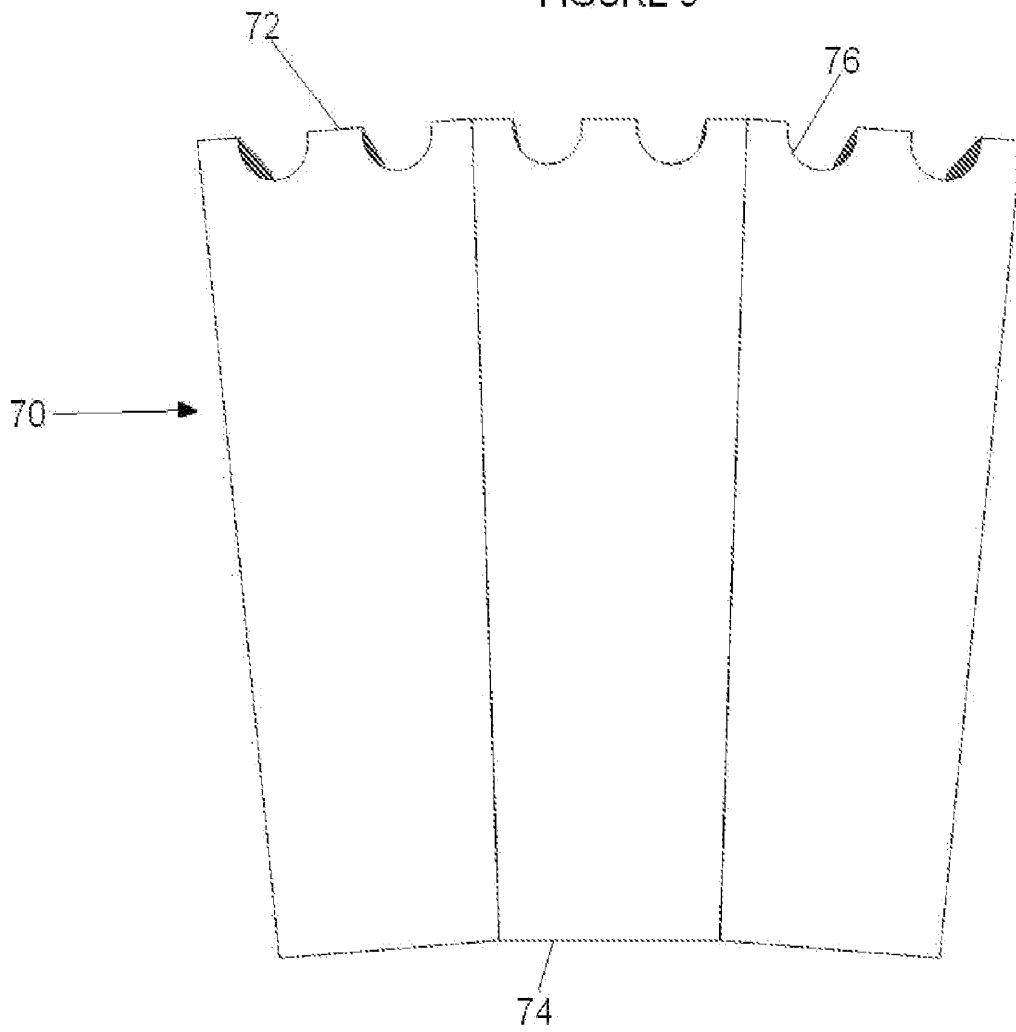

FIGURE 9



INSULATION BRICK

BACKGROUND

[0001] Vessels for holding high temperature materials, such as molten metal, are typically lined with a material to provide thermal insulation. Proper thermal insulation helps prevent thermal loss, saving energy and reducing the cost associated with preheating vessels. Thermal insulation also helps reduce the wear and tear on the vessel.

[0002] Vessels used to transport molten metals often undergo creep deformation caused by long exposure to high temperatures. Because creep increases with temperature, the less efficient the thermal insulation is, the greater the rate of creep will be. This can be a serious problem as the vessel may eventually deform to the point where it can no longer be used for its intended purpose and, in certain cases, deformation of the vessel may result in failure during use, posing a serious safety hazard.

[0003] An example of a vessel used to transport high temperature materials is a ladle used in the steelmaking process to transport molten metal from a blast furnace. Because of the high temperature associated with molten metal, the ladle undergoes extreme temperature swings. Over a period of time this results in creep deformation of the ladle's steel shell. The deformation has increased in modern steelmaking since carbon-containing refractory bricks were developed for use as linings in the early 1980s. The molten metal as well as the deformation of the ladle shell deteriorates the ladle brick lining and often leads to cracking and possibly catastrophic failures of both the lining and the shell. Lining a ladle with typical insulation brick can also be a time consuming and expensive task.

[0004] Numerous methods and devices have been developed in an attempt to improve the thermal efficiency of holding vessels. One of these methods utilizes a lining made from ceramic insulation board. This method, however, also suffers from drawbacks. Because ceramic insulation boards are typically highly porous, they have a tendency to shrink or abrade during use. This can lead to a loss of compression in the working linings, creating a gap between the bricks, and allow molten metal to penetrate the lining. This greatly reduces the thermal efficiency and can damage the vessel. Additionally, linings have been made by spraying refractory material over consumable insulation boards. The sprayed linings, however, are quickly degraded and must be replenished frequently. This can result in added expensive and a loss of productivity as the vessel is taken out of service to be relined.

SUMMARY

[0005] In an exemplary embodiment, the present invention is directed to an insulation brick. The insulation brick has an upper surface, a lower surface, a first end, a second end, an inner sidewall and an outer sidewall. The first end of the insulation brick has a convex portion while the second end of the insulation brick has a complementarily shaped concave portion. The outer sidewall of the insulation brick has a set of corrugations.

[0006] In an exemplary embodiment, the present invention is directed to a vessel for holding a high temperature material, preferably a molten metal. The vessel is a steel ladle having a shell with an outer wall and an inner wall. The steel ladle is lined with a first layer of insulation bricks having an upper surface, a lower surface, a first end, a second end, an inner

sidewall, and an outer sidewall. The outer sidewall has a set of corrugations. A second layer of insulation bricks having an upper surface, a lower surface, a first end, a second end, an inner sidewall, and an outer sidewall having a set of corrugations is placed on top of the first layer of insulation bricks. The outer sidewall of the insulation bricks are adjacent the inner wall of the steel ladle.

BRIEF DESCRIPTION OF THE DRAWINGS

[0007] FIG. 1 is a perspective view of an exemplary insulation brick.

[0008] FIG. 2 is a plane view of an exemplary insulation brick.

[0009] FIG. 3 is a perspective view an exemplary insulation brick and a sectional view of a vessel shell.

[0010] FIG. 4 is a perspective view of a mated pair of exemplary insulation bricks.

[0011] FIG. 5 is a plane view of a plurality of insulation bricks arranged in accordance with an exemplary embodiment of the invention.

[0012] FIG. 6 is a plane view of a plurality of insulation bricks arranged in accordance with an exemplary embodiment of the invention.

[0013] FIG. 7 is a plane view of an exemplary insulation brick.

[0014] FIG. 8 is a plane view of an array of exemplary insulation bricks.

[0015] FIG. 9 is a plane view of an array of exemplary insulation bricks.

DETAILED DESCRIPTION OF EXEMPLARY EMBODIMENT(S) AND EXEMPLARY METHOD(S)

[0016] Reference will now be made in detail to exemplary embodiments and methods of the invention as illustrated in the accompanying drawings, in which like reference characters designate like or corresponding parts throughout the drawings. It should be noted, however, that the invention in its broader aspects is not limited to the specific details, representative devices and methods, and illustrative examples shown and described in connection with the exemplary embodiments and methods.

[0017] Best shown in FIGS. 1 and 2 is an exemplary embodiment of an insulation brick 10. The insulation brick 10 has a top surface 12 and a bottom surface 14. The top and bottom surfaces 12, 14 may be planar or non-planar depending upon the vessel they are to be used with. The brick 10 has a first end 16 having a convex portion 18 and also a second end 20 having a concave portion 22, which is complementarily shaped to match the convex portion 18. The brick 10 has an outer sidewall 24 and an inner sidewall 26. In an exemplary embodiment, the first end 16 will transition directly from the convex portion 18 into the sidewalls 24, 26, while the second end 20 may have flat portions 28 connecting the sidewalls 24, 26 to the concave portion 22. Depending upon the vessel to be lined, the outer and inner sidewalls 24, 26 of the insulation brick 10 may have a radius of curvature. When dealing with a curved vessel, curved sidewalls 24, 26 allow the insulation brick 10 to conform to, and be arrayed about the vessel in close relationship to the sidewall of the vessel.

[0018] The insulation brick 10 may be formed from a variety of different materials depending on the vessel it is to be used with and the material properties of the industrial process.

For example, the brick **10** may be made from a composite having mostly alumina, for example 55-75%, and containing silica and other impurities such as Fe_2O_3 and TiO_2 . Also, a magnesia chrome brick may be used containing magnesia, Cr_2O_3 , Fe_2O_3 , CaO , and silica, for example 55-65% magnesia, 18-24% Cr_2O_3 , 3-6%, Fe_2O_3 , 0.8-1.2% CaO , and 0.5-1% silica. Or a high magnesia brick **10** may be used containing at least 95% magnesia.

[0019] As discussed in further detail below, the convex portion **18** of the insulation brick **10** is designed to mate with the concave portion **22** of a similar adjacent insulation brick. While this exemplary design is highlighted in this application, other mating arrangements such as a variety of male/female arrangements may be used with the insulation bricks **10** without departing from the spirit of the invention.

[0020] As best shown in FIGS. **1** and **2**, the outer sidewall **24** has a set of corrugations **30**. The quantity of the corrugations **30** will depend upon the length of the insulation brick **10**. In an exemplary embodiment, the insulation brick **10** will have between four and five corrugations **30**. The corrugations **30** may be a variety of shapes including curved or arcuate shapes such as cylindrical, spherical, or parabolic shapes, as well as channels, grooves, squares, or rectangular corrugations. In an exemplary embodiment the corrugations **30** are half cylinders. The corrugations **30** run the width of the insulation brick and, depending on the vessel to be lined and the desired thermal properties, may be different sizes. This may result in the corrugations **30** being in direct contact with each other or having intermediate planar portions **32**. Additionally, the depth of the corrugations **30** may vary. For example, a corrugation having a 1.25 inch diameter may have a depth of 0.75 inches, or a corrugation having a 0.75 inch diameter may have depth of 0.5 inches.

[0021] As best shown in FIG. **3**, the insulation bricks **10** are used to line a vessel having a shell **34**. The shell **34** comprises an outer wall **36** and an inner wall **38**. The outer sidewall **24** of the insulation brick **10** is placed adjacent the inner wall **38** of the shell **34**. As discussed above, the inner sidewall **26** preferably has a concave radius of curvature while the outer sidewall **24** has a convex radius of curvature. The curvature of the sidewalls **24**, **26** allows the insulation bricks **10** to conform to a curved shell **34**, though it is possible that only the outer sidewall **24** may need to be curved. Additionally, the curvature of the inner sidewall allows the lined vessel to maintain a maximum amount of holding space. The radius of curvature of the sidewalls **24**, **26** may vary depending on the curvature of the shell **34**. However, certain aspects of the invention, as discussed in further detail below, will allow the same shape of insulation brick **10** to be used in connection with a variety of shell configurations.

[0022] The corrugations **30** provide air pockets between the brick **10** and the shell **34** which increase the thermal insulation provided by the brick **10**. As discussed above, the size and shape of these corrugations may be optimized to provide an ideal or required amount of thermal insulation. The increased thermal insulation provided by the corrugations **30** allows for less material to be used, such as in forming a thinner brick **10** than typical. In an exemplary embodiment where the brick **10** is utilized in a steel ladle, the thickness of the brick can be approximately 3 inches. Additionally, the corrugations **30** can eliminate the need to provide additional temporary insulation, such as insulation fiber, that may be commonly applied to the outer sidewall **24**.

[0023] The number of corrugations **30** may be optimized to maintain a high level of insulation while maintaining good compression stress against flexing of the shell **34** during use. Adequate compression strength is important to prevent cracks from developing during such flexing. This is especially important when the insulation brick **10** is to be used with shells **34** having oval or obround configurations. These shapes are especially prone to flexing and difficult to operate with ceramic insulation boards for this reason. As mentioned above, four to five corrugations **30** result in greatly improved thermal efficiency while maintaining good compression stress against shell flexing. This, however, may vary depending on the length of the brick **10** and the size of the corrugations **30**. For example, in a brick **10** that is 9 inches in length, five corrugations having a diameter of 0.75 inches may be used, or four corrugations having a diameter of 1.25 inches may be used. In an exemplary embodiment, different configurations of brick **10** may be used in the same lining to provide optimal performance at different points of the shell **34**. Additionally, the planar portions **32** between the corrugations **30** will provide added strength to the insulation brick **10**.

[0024] To line a vessel, a series of insulation bricks **10** are placed together to encircle the ladle and further are arrayed in a series of layers vertically along the ladle. As best shown in FIG. **4**, a male portion of a first insulation brick **40** mates with the female portion of a second insulation brick **42**, connecting the two together. In an exemplary embodiment, the male portion is convex portion **18** of the first end **16** of the first insulation brick **40** and the female portion is the concave portion **22** of the second insulation brick **42**. By continuing this interconnection sequence, the insulation bricks can line a variety of different shapes and sized vessels. Because of the curved design of the insulation bricks ends **16**, **20**, the position of the bricks **40**, **42** may varied. The angle of the bricks **40**, **42** with respect to each other may be adjusted while maintaining a tight interface between the ends **16**, **20**. The angle of the bricks **40**, **42** along with the curvature of the sidewalls **24**, **26** enables the bricks **40**, **42** to create an efficient lining in vessels having a variety of shapes and sizes. This versatility provides an advantage over prior insulation means which had to be made or formed specifically for a certain vessel or container. Additionally the fit of the convex portion **18** and the concave portion **22**, can, in certain situations, eliminate the need to mortar between separate bricks **10**, as is typical with other insulation methods.

[0025] As best shown in FIGS. **5** and **6**, the bricks **10** can be aligned in a variety of different ways depending on the insulation requirements for the holding vessel. Because the corrugations **30** do not extend along the entire length of the brick **10**, the thermal insulation advantages will also not be achieved along the entire length of the brick. In certain cases, it may be advantageous to evenly distribute the corrugations **30** along different layers. As best shown in FIG. **5**, a first layer of brick **44** is offset from the second layer **46**. This allows the corrugations **30** of the second layer of bricks **46** to be over the mating concave convex portions **18**, **22** of the first layer of bricks **44**. Additional layers of brick, if needed, may be then arranged so that they are in the same position as the first layer **44**, or further offset in the direction of the second layer **46**. The amount of the offset may be equal to the offset between the first layer **44** and the second layer **46**, or it may vary.

[0026] As best shown in FIG. **6**, the first layer of brick **44** may be aligned with the second layer of brick **46**, so that a continuous channel is formed by the corrugations **30**. A third

layer 48, if necessary, may then either be aligned with the first and second layers 44, 46, or, as shown in FIG. 6, may be offset. Additionally, the bricks 10 may be placed at random, though providing organization to the bricks allows for great control of the heat transfer to a vessel's shell.

[0027] As best shown in FIGS. 7-9, a variety of different types of insulation bricks can be used in conjunction with this aspect of the invention. FIG. 7 shows a flat rectangular brick 50 having an outer sidewall 52 and an inner sidewall 54. The outer sidewall 52 has a set of corrugations 56. Rectangular brick 50 is best used for non-curved shaped vessels.

[0028] FIG. 8 shows an array of key shaped bricks 60 having an outer sidewall 62 and an inner sidewall 64. The outer sidewall has a set of corrugations 66. The outer sidewall 62 is longer than the inner sidewall 64, so that the brick has angled sides and can be placed together in the array as shown. This will enable the key shaped brick 60 to be used with various shapes of vessels such as those that may be curved or have a polygonal configuration.

[0029] FIG. 9 shows an array of narrow rectangular shaped bricks 70 having an outer sidewall 72 and an inner sidewall 74. The outer sidewall has a set of corrugations 76. As with the key shaped brick 60, the narrow rectangular bricks can have an outer sidewall 72 with a length greater than the inner sidewall 74 to enable the bricks 70 to be placed in an angled array.

[0030] The foregoing description of the exemplary embodiments of the present invention has been presented for the purpose of illustration. It is not intended to be exhaustive or to limit the invention to the precise forms disclosed. Obvious modifications or variations are possible in light of the above teachings. The embodiments disclosed hereinabove were chosen in order to best illustrate the principles of the present invention and its practical application to thereby enable those of ordinary skill in the art to best utilize the invention in various embodiments and with various modifications as are suited to the particular use contemplated, as long as the principles described herein are followed. Thus, changes can be made in the above-described invention without departing from the intent and scope thereof. Moreover, features or components of one embodiment may be provided in another embodiment. Thus, the present invention is intended to cover all such modification and variations.

1. An insulation brick comprising:
 - an upper surface;
 - a lower surface;
 - a first end having a convex portion;
 - a second end having a concave portion;
 - an inner sidewall; and
 - an outer sidewall comprising a set of corrugations.

2. An insulation brick according to claim 1, wherein the convex portion of said first end is designed to mate with the convex portion of the second end of a similar insulation brick.

3. An insulation brick according to claim 1, wherein the set of corrugations includes 3 to 6 corrugations.

4. An insulation brick according to claim 1, wherein said inner sidewall has a first radius of curvature.

5. An insulation brick according to claim 4, wherein said inner sidewall has a concave curvature.

6. An insulation brick according to claim 5, wherein said outer sidewall has first radius of curvature.

7. An insulation brick according to claim 6, wherein said outer sidewall has a convex radius of curvature.

8. An insulation brick according to claim 1, wherein the corrugations are cylindrical.

9. An insulation brick according to claim 1, further comprising planar portions separating the corrugations.

10. An insulation brick according to claim 1, further comprising a planar portion connecting the concave portion of said second end to said outer and inner sidewalls.

11-23. (canceled)

24. An insulation brick accordingly to claim 1, wherein the insulation brick comprises 55% to 75% alumina by weight.

25. An insulation brick accordingly to claim 1, wherein the insulation brick comprises 55% to 65% magnesia by weight.

26. An insulation brick comprising:

- an upper surface;
- a lower surface;
- an inner sidewall;
- an outer sidewall comprising a corrugation; and
- a first side and a second side, the first and second sides extending from the outer sidewall to the inner sidewall.

27. An insulation brick of claim 26, wherein the inner sidewall has a first length and the outer sidewall has a second length greater than the first length.

28. An insulation brick of claim 27, wherein the outer sidewall comprises three corrugations.

29. An insulation brick according to claim 27, wherein the corrugations are cylindrical.

30. An insulation brick according to claim 29, further comprising planar portions separating the corrugations.

31. An insulation brick according to claim 29, wherein the corrugations have a diameter 1.25 inches.

32. An insulation brick accordingly to claim 27, wherein the insulation brick comprises 55% to 75% alumina by weight.

33. An insulation brick accordingly to claim 27, wherein the insulation brick comprises 55% to 65% magnesia by weight.

* * * * *